

YASKAWA AC Drive - A1000

Spindle Orientation

Custom Software Supplement

Software Number: VSA91009□

Drive Models: 200 V Class, CIMR-AU2A0004□A□-063 to CIMR-AU2A0415□A□-063
400 V Class, CIMR-AU4A0002□A□-063 to CIMR-AU4A0250□A□-063

To properly use the product, read this manual thoroughly and retain for easy reference, inspection, and maintenance. Ensure the end user receives this manual.

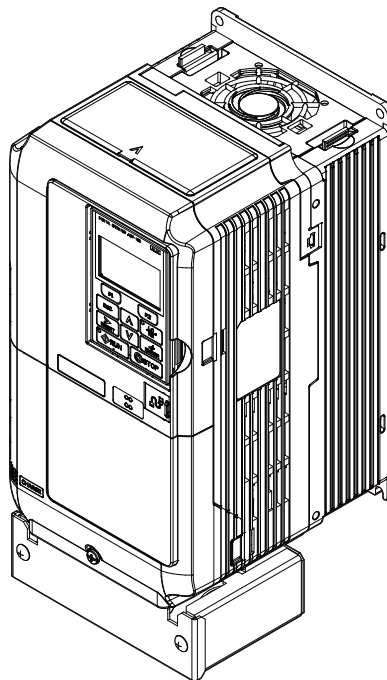



Table of Contents

- 1 PREFACE AND SAFETY 5
- 2 SPINDLE ORIENTATION 6
- 3 REVISION HISTORY 34

Refer to the A1000 Technical Manual for content not described in this document.

Copyright © 2011 YASKAWA AMERICA, INC.

All rights reserved. No part of this publication may be reproduced, stored in a retrieval system, or transmitted, in any form or by any means, mechanical, electronic, photocopying, recording, or otherwise, without the prior written permission of Yaskawa. No patent liability is assumed with respect to the use of the information contained herein. Moreover, because Yaskawa is constantly striving to improve its high-quality products, the information contained in this manual is subject to change without notice. Every precaution has been taken in the preparation of this manual. Yaskawa assumes no responsibility for errors or omissions. Neither is any liability assumed for damages resulting from the use of the information contained in this publication.

This Page Intentionally Blank

1 Preface and Safety

Yaskawa manufactures products used as components in a wide variety of industrial systems and equipment. The selection and application of Yaskawa products remain the responsibility of the equipment manufacturer or end user. Yaskawa accepts no responsibility for the way its products are incorporated into the final system design. Under no circumstances should any Yaskawa product be incorporated into any product or design as the exclusive or sole safety control. Without exception, all controls should be designed to detect faults dynamically and fail safely under all circumstances. All systems or equipment designed to incorporate a product manufactured by Yaskawa must be supplied to the end user with appropriate warnings and instructions as to the safe use and operation of that part. Any warnings provided by Yaskawa must be promptly provided to the end user. Yaskawa offers an express warranty only as to the quality of its products in conforming to standards and specifications published in the Yaskawa manual. **NO OTHER WARRANTY, EXPRESS OR IMPLIED, IS OFFERED.** Yaskawa assumes no liability for any personal injury, property damage, losses, or claims arising from misapplication of its products.

◆ Applicable Documentation

The following manuals are available for the A1000 Drive:

Custom Software Supplement

	Yaskawa AC Drive - Spindle Orientation A1000 Custom Software Supplement Manual No: TM.A1000SW.063
	Read this manual first. This supplement is an addendum to the A1000 Quick Start Guide and Technical Manual. It lists the effects of this custom software on the parameters in the drive and function descriptions in the manual. To obtain the supplement access this site: U.S: http://www.yaskawa.com

Yaskawa Drive

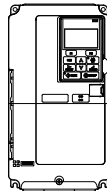
	Yaskawa AC Drive - A1000 Quick Start Guide	To obtain instruction manuals for Yaskawa products access these sites: U.S.: http://www.yaskawa.com Europe: http://www.yaskawa.eu.com Japan: http://www.e-mechatronics.com Other areas: contact a Yaskawa representative. For questions, contact the local Yaskawa sales office or the nearest Yaskawa representative.
	Yaskawa AC Drive - A1000 Technical Manual	

◆ Supplemental Safety Information

Read and understand this manual and the A1000 Quick Start Guide before installing, operating, or servicing this option unit. Install the drive according to the A1000 Quick Start Guide and local codes. Observe all cautions and warnings in this document and the standard drive technical manuals.

Refer to the A1000 Quick Start Guide and Technical Manual for safety information and to install and start-up the drive.

This document is a supplement to the standard drive technical manual. It describes the effects on the drive parameters and functions with the software installed.

- Custom software is provided to add functionality to a standard drive to enhance or enable use in a specific application.
- The software is loaded to the flash ROM area of the control board, and replaces the standard drive software.

◆ Obtaining Support

When seeking support for a drive with custom software, it is imperative to provide the unique part number shown on the drive nameplate. The software is flashed to the control board memory and the operation of parameters, functions, and monitors are different than the standard drive software, as described herein.

Refer to Yaskawa office locations listed on the back cover of this manual.

2 Spindle Orientation

◆ Overview

The target applications for this function are on equipment that must stop in specific positions including tool changing for machine tool spindles and die changing for punch/stamping presses. This software also provides automatic switchover to closed-loop operation at low speed.

◆ Applicable Models

This Spindle Orient software is available for the drive models listed in [Table 1](#).

Table 1 Applicable Models

Voltage Class	Model	Software Version
200 V	CIMR-AU2A0004□A□-063 to CIMR-AU2A0415□A□-063	VSA91009x
400 V	CIMR-AU4A0002□A□-063 to CIMR-AU4A0250□A□-063	

◆ Basic Concepts and Principles

This orientation software allows an A1000 drive to repeatedly stop a machine at a certain point in its rotational cycle. This is accomplished by means of an orientation encoder directly coupled to the machine part to be positioned. A simple example is to think of the hands on a clock. If the orientation encoder is mounted to the motor shaft, this software can stop the motor so that the spindle stops at the 3 o'clock position every time. Application configurations are outlined in [Figure 1](#). For configurations other than those outlined, contact Yaskawa Application Engineering before applying this software.

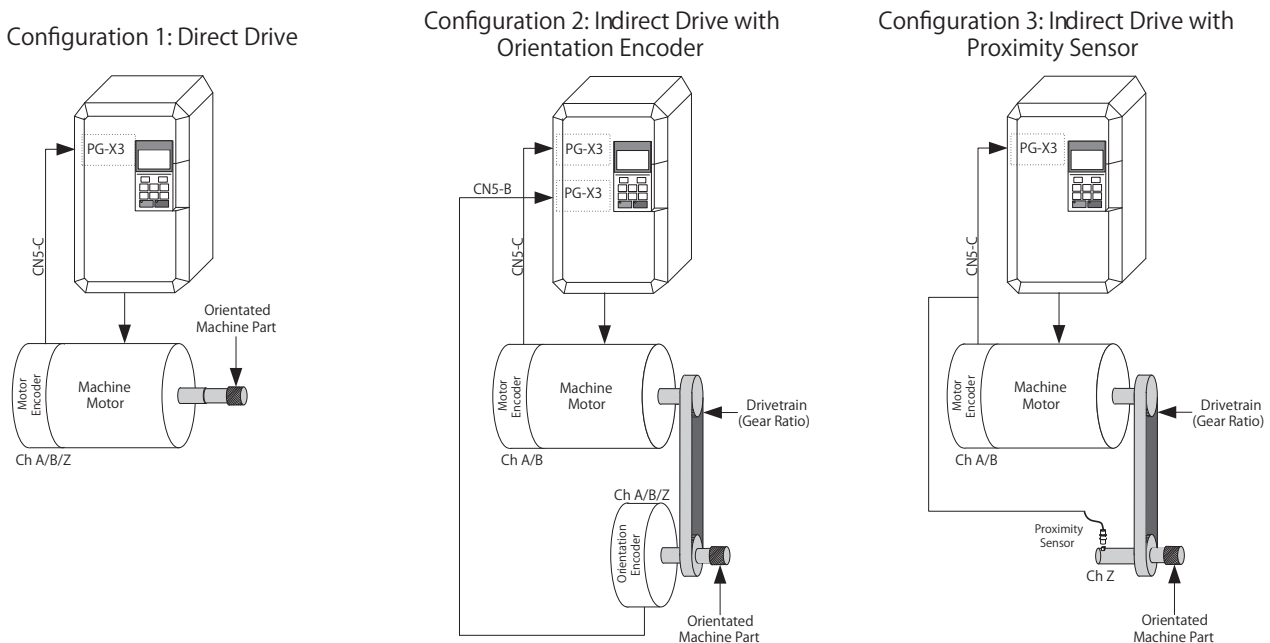

Figure 1 Spindle Orientation Hardware Configurations

■ Direct Drive

In the first configuration, the drive motor directly drives the machine part being oriented (positioned). When using this method, the motor encoder is used for both closed loop vector control and for orientation. This encoder must have a C or Z channel which provides a “marker” or “index” pulse with every rotation. If the encoder does not have a C/Z channel, an external marker pulse can be implemented as outlined in [Encoder \(PG\) Option Card Configuration and Wiring on page 29](#). Additionally, a PG-X3 or PG-B3 encoder (PG) feedback option card is required to connect the encoder to the drive.

■ Indirect Drive with Orientation Encoder

When the motor and the machine part to be oriented (positioned) are connected through a drive train with a constant ratio, two encoders are required. The first encoder is mounted on the driven motor, and the second, an orientation encoder, is mounted on the machine part to be oriented. The orientation encoder must have a C or Z channel which provides a “marker” or “index” pulse with every rotation. If the encoder does not have a C/Z channel, an external marker pulse can be implemented as outlined in [Encoder \(PG\) Option Card Configuration and Wiring on page 29](#). The motor encoder does not need to have a C/Z channel. Two encoder (PG) feedback option cards are required for this setup.

■ Indirect Drive with Proximity Sensor

When the motor and the spindle are connected through a drive train and the spindle does not have its own encoder, a proximity sensor may be used. The proximity sensor is connected as an external marker pulse; therefore this configuration requires only one PG-X3 encoder (PG) feedback option card. In this configuration, the gear ratio of the drive train must be expressed as the number of revolutions of the motor per revolution of the spindle.

■ Online Control Mode Switch Function

This software can switch between Closed Loop Vector Control and V/f Control during run. The 590 Hz software is limited to V/f control mode above 400 Hz, it is possible to change tools without stopping the machine if the inverter switches to Closed Loop Vector Control for Position Control at Low-Speed. At Low-Speed the inverter can be set to operate in Closed Loop Vector Control and automatically switch to V/f Control when the output is above the frequency which is set.

◆ Changes from the Standard Product

- Second PG Channel Parameters F1-30 through F1-37 are always visible whether or not digital selection H1-0□ =16 (Motor 2 Select) is programmed.
- Only two Control Modes can be set in A1-02 and E3-01, 0:V/f and 3:Closed-Loop Vector.
- Only two Auto-Tuning Mode Selections are available, 0:Rotational Auto-Tuning and 2:Stationary Auto-Tuning for Line-to-Line Resistance.

■ Deleted Functions

Certain functions in the standard software of A1000 are deleted in this Orientation software. Deleted functions are listed in [Table 2](#).

Table 2 Deleted Functions

Function Name		
Speed Search (all methods)	KEB Function	Fault Restart
High Slip Braking (HSB)	Overexcitation Braking	Field Weakening Function
Energy Savings	Droop Control	Field Forcing Function
Frequency Reference Lower Limit	Feed Forward Control	DC Injection Braking Current Setting in V/f
Torque Detection	Stall Prevention Selection during Acceleration	Stall Prevention Selection during Run

2 Spindle Orientation

◆ Limitations

- The multi-function digital input function Motor 2 Select (H1-□□ = 16) and Encoder Option Card Setting F1-30 have restrictions when used in Closed Loop Vector control mode with an additional orientation encoder. Refer to [Table 15](#) on page 16 and [Table 17](#) on page 31.
- Applications using Configuration 2 and Motor 1/Motor 2 switchover must use a motor encoder and an orientation encoder of the same PPR.
- DriveWorks EZ functionality is not fully supported when using this software. If DriveWorks EZ support is required, please contact Yaskawa Application Engineering.
- PG Encoder PPR parameters F1-01 and F1-31 are limited to PPR of 8 to 16384 PPR (32 to 65536 counts per revolution).
- Orient functionality is disabled when the run command comes from the Local Operator (b1-02 = 0).
- Since all forms of speed search are disabled, the stopping method Coast to Stop (b1-03 = 1) causes inconsistent operation of the spindle orient routine if an orient digital input is closed while the drive is coasting. This may include but is not limited to overvoltage trips and faster than expected deceleration.
- Disabling reverse operation by setting Reverse Operation Selection parameter b1-04=1 prohibits the orient function from maintaining position.
- Frequency Upper Limit parameter d2-01 prevents the spindle orient function from operating if the frequency limit is set at or below the P1-02 Creep Speed.
- Orient digital inputs are disabled when Forward or Reverse Jog commands (H1-0□ = 12 or 13) are active.
- Orient digital inputs are disabled when Control Mode Switchover Prevention digital input H1-0□ = 50 is closed while the drive is not running.

◆ Related Parameters and Functions

The legend below is used in this section to indicate which parameters are available in which control modes.

The parameter tables in this section are used to set up the drive for operation with the software.

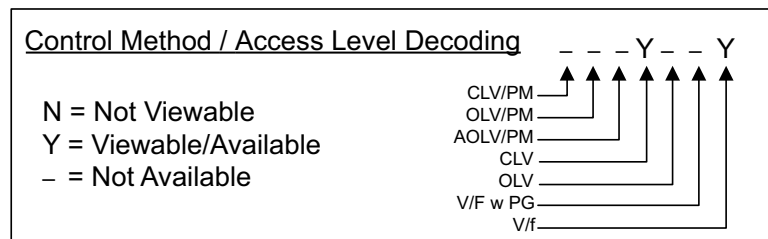

Note: Chinese language support is added to certain parameters and functions. [Refer to References on page 31](#) for the parameters and functions with Chinese language support.

Table 3 Modified Parameters

No.	MEMOBUS/ Modbus Address	Name Digital Operator Display	Description	Range	Default Value	Change During Run	Control Method/ Access Level
F1-01	0380h	PG 1 Pulses Per Revolution PG1 Pulses/Rev	Sets the number of encoder pulses per revolution for the encoder on channel 1.	8 to 16384 PPR	1024 PPR	No	- - - Y - - N
F1-30	03AAh	PG Option Card Port for Motor 2 Selection Mtr2 PG Port Sel	Specifies the drive port for the PG option card used for Motor 2. 0: CN5-C 1: CN5-B Note: This parameter is available without a digital input H1-0□ programmed to 16h (Motor 2 Select).	0 to 1	0	No	- - - Y - - N

2 Spindle Orientation

No.	MEMOBUS/ Modbus Address	Name Digital Operator Display	Description	Range	Default Value	Change During Run	Control Method/ Access Level
F1-31	03B0h	PG 2 Pulses Per Revolution PG2 Pulses/Rev	Sets the number of encoder pulses per revolution for the encoder on channel 2. Note: This parameter is available without a digital input H1-0□ programmed to 16h (Motor 2 Select).	8 to 16384 PPR	1024 PPR	No	--- Y-- N
F1-32	03B1h	PG2 Rotation Selection PG2 Rotation Sel	Determines the direction indicated by the pulses from the PG feedback encoder for motor 2. 0: Pulse A Leads 1: Pulse B Leads This parameter is available without a digital input H1-0□ programmed to 16h (Motor 2 Select).	0 to 1	0	No	--- Y-- N
F1-35	03BEh	PG2 Division Rate for Pulse Monitor PG2 Output Ratio	Sets the ratio between the pulse input and the pulse output of a PG option card. This parameter is available without a digital input H1-0□ programmed to 16h (Motor 2 Select).	1 to 132	1	No	--- Y-- N
F1-36	03B5h	PG Option Card Disconnect Detection 2 PGCardDisconDet1	Sets whether the drive detects a fault when a PG-X3 card is disconnected. 0: Disabled 1: Enabled This parameter is available without a digital input H1-0x programmed to 16h (Motor 2 Select).	0 to 1	1	No	--- Y-- N
L3-04	0492h	Stall Prevention Selection during Deceleration StallP Decel Sel	Determines how Stall Prevention works during Run. The parameter default is changed to 0: Disabled. 0: Disabled 1: General Purpose 2: Intelligent 3: Stall Prevention w/Braking Resistor 4: Overexcitation Deceleration 5: Overexcitation Deceleration 2 Note: Enabling stall prevention extends the decel time. Other modes such as Intelligent may cause unintended operation during orient, including oscillation and inability to maintain position.	0 to 5	0	No	--- Y-- Y
S1-01	680h	On-Delay Compensation Selection OnDelay Comp Sel	Parameter S1-01 is used to enable and disable On Delay Compensation. 0: Disabled 1: Enabled	0 to 1	1	No	--- Y-- Y
S1-03	682h	Extended Current Sampling Mode Extend I Sample	Normally there is no need to change S1-03 from its default setting. If there is a problem with output voltage weakening when attempting to compensate for output current distortion as the motor reaches 590 Hz while decoupled from the load during a test run, then try setting S1-03 = 1. 0: Disabled 1: Enabled	0 to 1	1	No	--- Y-- Y
S2-01	691h	Control Mode Switchover Frequency HF SwOver Freq	Sets the frequency of switching from Closed Loop Vector Control to V/f Control. This function is disabled when 0 or 400 Hz is set, the inverter runs as V/f Control when 0 is set and Closed Loop Vector Control when 400 Hz is set. However, OPE21 occurs when the relations among Control Mode Switch Frequency (S2-01) and PG Pulse per Revolution (F1-01) and Numbers of Motor Poles (E2-04) are set higher than the permissible input frequency of PG option.	0 to 400 Hz	400	No	--- Y-- N
S2-02	692h	Control Mode Switchover Bandwidth HF CtrlMode SwBW	Sets the hysteresis width of Control Mode Switch. Increase if shock occurs during Control Mode switching.	2 to 100 Hz	20	No	--- Y-- N

2 Spindle Orientation

No.	MEMOBUS/ Modbus Address	Name Digital Operator Display	Description	Range	Default Value	Change During Run	Control Method/ Access Level
S2-05	695h	High Frequency Slip Compensation Gain HF SlipComp Gain	Sets the gain for the Motor Slip Compensation at Hi-Speed Function. Although this parameter rarely needs to be changed, adjustments might be needed under the following circumstances: If the motor at constant speed is slower than the frequency reference, increase S2-05. If the motor at constant speed is faster than the frequency reference, decrease S2-05.	0.0 to 2.5	0.0	Yes	--- Y-- N
S2-06	696h	High Frequency Slip Compensation Primary Delay Time HF SlipComp Time	Sets the filter on the output side of the Slip Compensation at Hi-Speed Function. Although this parameter rarely needs to be changed, adjustments might be needed under the following circumstances: -Decrease the setting when the slip compensation response is too slow. -Increase this setting when speed is unstable.	0 to 10000 ms	2000	Yes	--- Y-- N
S2-07	697h	High Frequency Slip Compensation Limit HF SlipComp Lim	Sets the upper limit for the Slip Compensation at Hi-Speed Function as a percentage of the motor rated slip (E2-02).	0 to 250%	200	No	--- Y-- N
S2-08	698h	High Frequency Slip Compensation Selection During Regeneration HF SlipCompRegen	When Slip Compensation during Regeneration at Hi-Speed is activated and a regenerative load is applied, it might be necessary to use a dynamic braking option (braking resistor, braking resistor unit, or braking unit). 0: Disabled 1: Enabled (6 Hz and Above) 2: Enabled (Compensation provided wherever possible)	0 to 2	0	No	--- Y-- N
S2-11	699h	Motor 2 Control Mode Switchover Frequency HF SwOver Freq 2	Sets the frequency of switching from Closed Loop Vector Control to V/f Control for Motor 2 This function is disabled when 0 or 400Hz is set, the inverter runs as V/f Control when 0 is set, and Closed Loop Vector Control when 400Hz is set. However, OPE21 occurs when the relations among Control Mode Switch Frequency (S2-11) and PG Pulse per Revolution (F1-31) and Numbers of Motor Poles (E4-04) are set higher than the permissible input frequency of PG option.	0 to 400 Hz	400	No	--- Y-- N
S2-12	69Ah	Motor 2 Control Mode Switchover Bandwidth HF CtrlModeSwBW2	Sets the hysteresis width of Control Mode Switch for Motor 2. Increase if shock occurs during Control Mode switching.	2 to 100 Hz	20	No	--- Y-- N
S2-15	69Dh	Motor 2 High Frequency Slip Compensation Gain HF SlipCompGain2	Sets the gain for the Motor Slip Compensation at Hi-Speed Function for Motor 2. Although this parameter rarely needs to be changed, adjustments might be needed under the following circumstances: -If the motor at constant speed is slower than the frequency reference, increase S2-15. -If the motor at constant speed is faster than the frequency reference, decrease S2-15.	0.0 to 2.5	0.0	Yes	--- Y-- N
S2-16	69Eh	Motor 2 High Frequency Slip Compensation Primary Delay Time HF SlipCompTime2	Sets the filter on the output side of the Slip Compensation at Hi-Speed Function for Motor 2. Although this parameter rarely needs to be changed, adjustments might be needed under the following circumstances: -Decrease the setting when the slip compensation response is too slow. -Increase this setting when speed is unstable.	0 to 10000 ms	2000	Yes	--- Y-- N
S2-17	69Fh	Motor 2 High Frequency Slip Compensation Limit HF SlipComp Lim2	Sets the upper limit for the Slip Compensation at Hi-Speed Function for Motor 2 as a percentage of the motor rated slip (E4-02).	0 to 250%	200	No	--- Y-- N

No.	MEMOBUS/ Modbus Address	Name Digital Operator Display	Description	Range	Default Value	Change During Run	Control Method/ Access Level
S2-18	6A0h	Motor 2 High Frequency Slip Compensation During Regeneration Selection HF SlipCompRgn 2	When Slip Compensation during Regeneration at Hi-Speed is activated and a regenerative load is applied, it might be necessary to use a dynamic braking option (braking resistor, braking resistor unit, or braking unit). 0: Disabled 1: Enabled (6 Hz and Above) 2: Enabled (Compensation provided wherever possible)	0 to 2	0	No	---Y--N

Table 4 Additional Parameters

No.	MEMOBUS/ Modbus Address	Name Digital Operator Display	Description	Range	Default Value	Change During Run	Control Method/ Access Level
P1-01	0600h	Orient Speed Orient Speed	This parameter sets the frequency at which the drive switches to the Orient Deceleration Time (P1-12) and Orient ASR settings (P2-10 and P2-11) when these parameters are enabled. Note: P1-01 must be set such that it is not greater than the control modes switchover frequency: ((S2-01 – S2-02) > P1-01). P1-01 must also be set lower than the Maximum Output Frequency E1-04.	0.00 to 200.00 Hz	20.00	No	---Y--N
P1-02	0601h	Creep Speed Creep Speed	This parameter sets the speed at which the drive locates the marker pulse. This is also the speed at which s-curves are disabled.	0.10 to 10.00 Hz	2.00	No	---Y--N
P1-03	0602h	Creep Distance Creep Distance	This parameter sets the number of quadrature encoder counts around the orientation position where the frequency reference is allowed to drop below the P1-02 Creep Speed. Within the Creep Distance, the drive accel/decel times are set to 0.	0 to 2000 Cnts	200	No	---Y--N
P1-04	0603h	Approach Speed Approach Speed	This parameter sets the minimum speed that the drive operates at until it reaches the P1-05 ORT Set Window.	0.00 to 1.00 Hz	0.10	No	---Y--N
P1-05	0604h	Orientation Complete Detection Set Window ORT Set Window	This parameter sets the initial window around the orientation position that activates the Orient Complete digital output. The Orient Complete digital output (H2-□□ = 40) closes when the encoder quadrature count is within the P1-05 window of the orientation offset and after the P1-07 delay time has expired. Note: Counts = Encoder PPR x 4.	0 to 100 Cnts	25	No	---Y--N
P1-06	0605h	Orientation Complete Detection Reset Window ORT Rst Window	This parameter sets, in quadrature encoder counts, the window around the orient position that keeps the Orient Complete digital output (H2-□□ = 40) closed. Note: Counts = Encoder PPR x 4.	0 to 100 Cnts	0	No	---Y--N
P1-07	0606h	Orientation Set Time ORT Set Time	This parameter sets the delay time from when the P1-05 Orient Set window is satisfied and the Orientation Complete digital output (H2-□□ = 40) closes.	0 to 1000 ms	10	No	---Y--N
P1-08	0607h	Positioning Proportional Gain Pos P Gain	This parameter sets the proportional gain used for the position controller.	0.10 to 20.00	1.00	No	---Y--N
P1-09	0608h	Orientation Compensation Distance Orient Comp Dist	This parameter sets the minimum orientation distance between the orientation encoder marker pulse at or below P1-02 and the desired orientation offset. This distance is expressed as a percentage of the active encoder PPR (e.g. F1-01 x P1-09).	0 to 100%	50%	No	---Y--N

2 Spindle Orientation

No.	MEMOBUS/ Modbus Address	Name Digital Operator Display	Description	Range	Default Value	Change During Run	Control Method/ Access Level
P1-10	0609h	Orientation Encoder Card Selection ORT Enc Select	This parameter selects which PG option card is used for orientation. 0: CN5-C 1: CN5-B Note: When using only one PG option card, P1-10 must be set to 0.	0 to 1	0	No	--- Y-- N
P1-11	061Eh	Orientation Deceleration Selection ORT Dec Sel	This parameter selects whether the drive's C1-0□ Deceleration Time is overridden by the P1-12 Orientation Deceleration Time once the drive reaches the P1-01 Orient Speed. 0: Disabled 1: Enabled	0 to 1	0	No	--- Y-- N
P1-12	061Fh	Orientation Deceleration Time ORT Dec Time	The Orientation Deceleration Time parameter sets the time to decelerate from the maximum output frequency (E1-04) to 0 Hz. <i>Refer to Area A: Deceleration on page 19</i>	0.00 to 600.00 sec	10.00	Yes	--- Y-- N
P1-13	0620h	Spindle Proximity Sensor Orientation Enable Prox Sens Enable	This parameter selects whether or not the drive is configured with a proximity sensor as described in Configuration 3. Setting parameter P1-13 = 1 causes the drive to recognize the values set in proximity sensor parameters P1-14 and P1-15. 0: Disabled 1: Enabled	0 to 1	0	No	--- Y-- N
P1-14	0621h	Proximity Sensor Pulse Width Prox Pulse Width	This parameter defines the pulse width of the proximity sensor at the P1-02 Creep Speed, measured in elapsed encoder counts.	0 to 60000 Cnts	0	No	--- Y-- N
P1-15	0622h	Proximity Sensor Pulse State Prox Pulse State	This parameter defines whether or not the proximity sensor is a Normally Open (rising edge) or Normally Closed (falling edge). 0: Normally Open 1: Normally Closed	0 to 1	0	No	--- Y-- N
P2-01	060Ah	Marker Offset Selection MarkerOffset Sel	This parameter determines how the orientation position offset from the marker pulse is determined. 0: Digital Input 1: Sequential 2: Memobus COM <i>Refer to Orient Position Offset Selection on page 25.</i>	0 to 2	0	No	--- Y-- N
P2-02	060Bh	Marker Offset 1 Marker Offset 1	This parameter, along with parameters P2-03, P2-04, and P2-05, sets the orientation (or stopped) position of the machine. P2-01 governs when P2-02 is active. <i>Refer to Orient Position Offset Selection on page 25.</i> Note: Counts = Encoder PPR x 4.	0 to 65535 Cnts	0	No	--- Y-- N
P2-03	060Ch	Marker Offset 2 Marker Offset 2	This parameter is used in conjunction with parameters P2-02, P2-04, and P2-05 to determine the orientation position offset from the marker pulse. <i>Refer to Orient Position Offset Selection on page 25.</i> Note: Counts = Encoder PPR x 4.	0 to 65535 Cnts	0	No	--- Y-- N
P2-04	060Dh	Marker Offset 3 Marker Offset 3	This parameter is used in conjunction with parameters P2-02, P2-03, and P2-05 to determine the orientation position offset from the marker pulse. <i>Refer to Orient Position Offset Selection on page 25.</i> Note: Counts = Encoder PPR x 4.	0 to 65535 Cnts	0	No	--- Y-- N
P2-05	060Eh	Marker Offset 4 Marker Offset 4	This parameter is used in conjunction with parameters P2-02, P2-03, and P2-04 to determine the orientation position offset from the marker pulse. <i>Refer to Orient Position Offset Selection on page 25.</i> Note: Counts = Encoder PPR x 4.	0 to 65535 Cnts	0	No	--- Y-- N

No.	MEMOBUS/ Modbus Address	Name Digital Operator Display	Description	Range	Default Value	Change During Run	Control Method/ Access Level
P2-06	060Fh	Motor Gear Ratio 1 Motor Ratio 1	This parameter sets gear ratio 1 between the driven motor shaft and the spindle when the drive is set for an indirect drive configuration. A setting of 2.0000 means that there are two motor shaft revolutions for every revolution of the spindle. <i>Refer to Configuration 2: Indirect Drive with Orientation Encoder on page 23.</i>	0.0400 to 2.5000	1.0000	No	---Y--N
P2-07	0610h	Motor Gear Ratio 2 Motor Ratio 2	This parameter sets gear ratio 2 between the driven motor shaft and the spindle.	0.0400 to 2.5000	1.0000	No	---Y--N
P2-08	0611h	Motor Gear Ratio 3 Motor Ratio 3	This parameter sets gear ratio 3 between the driven motor shaft and the spindle.	0.0400 to 2.5000	1.0000	No	---Y--N
P2-09	0612h	Orientation ASR Enable ORT ASR Enable	This parameter enables the ASR Proportional Gain override used during orientation. 0: Disabled 1: Enabled	0 to 1	0	No	---Y--N
P2-10	0613h	ASR P Gain 3 ASR P Gain 3	This parameter sets the ASR Proportional Gain used for orientation and becomes active whenever an Orient Digital Input (H1-0□ = 80 ~ 82) is present. This parameter overrides C5-01 and C5-03 when P2-09 = 1. The active proportional gain (C5-01 or C5-03) is ramped to the P2-10 value using the P2-11 time setting.	0.00 to 300.00	20.00	Yes	---Y--N
P2-11	0623h	ASR I Time 3 ASR I Time 3	This parameter sets the ASR Integral Time used for orientation and becomes active whenever an Orient Digital Input (H1-0□ = 80 ~ 82) is present. This parameter automatically overrides C5-02 and C5-04.	0.000 to 10.000 sec	0.500	Yes	---Y--N
P2-12	0624h	ASR P Gain 4 ASR P Gain 4	This parameter sets the ASR Proportional Gain used for orientation and becomes active whenever the Orientation Complete Digital Output (H2-0□ = 40) is active. This parameter overrides C5-01, C5-03, and P2-10 ASR gain settings when P2-09 = 1. The active P2-10 proportional gain is ramped to the P2-12 value using the P2-13 time setting.	0.00 to 300.00	20.00	Yes	---Y--N
P2-13	0625h	ASR I Time 4 ASR I Time 4	This parameter sets the ASR Integral Time used for orientation and becomes active whenever the Orientation Complete Digital Output (H2-0□ = 40) is active. This parameter automatically overrides C5-02, C5-04, and P2-11.	0.000 to 10.000 sec	0.500	Yes	---Y--N

Table 5 Modified Group Text

Function Group	Function Group Name Digital Operator Display
S	High Frequency High Frequency

Table 6 Additional Group Text

Function Group	Function Group Name Digital Operator Display
P	Spindle Orient Group Spindle Orient

Table 7 Modified Function Text

Function No.	Function Name Digital Operator Display
S1	High Frequency Control HighFreq Control
S2	Control Mode Switchover Ctrl Mode Switch

2 Spindle Orientation

Table 8 Additional Function Text

Function No.	Function Name Digital Operator Display
P1	Orient Settings Orient Settings
P2	Offset and Gear Ratio Offset & Gear

Table 9 Monitor Function Text

Monitor No.	Monitor Name Digital Operator Display
U7	Spindle Orient Group Spindle Orient

Table 10 Monitors

Monitor No.	MEMOBUS/ Modbus Address	Monitor Name Digital Operator Display	Description	Analog output scaling	Unit	Control Method/ Access Level
U7-02	0661h	Distance From Marker Dist From Marker	Displays the current number of orientation encoder counts the machine is past the marker pulse. The display range is 0 - 65535 counts and is limited by the PPR setting in parameters F1-01 and F1-31. Note: Counts = Encoder PPR x 4.	Full scale: 65535 Counts	Cnts	---Y--Y
U7-03	0662h	Distance From Offset Dist From Offset	Displays the number of orientation encoder counts the machine is away from the active orientation position offset. The display range is 0 - 65535 counts.	Full scale: 65535 Counts	Cnts	---Y--Y
U7-04	0663h	Commanded Offset Commanded Offset	Displays the active value of the orientation offset from the marker pulse. See parameter P2-01 <i>Orient Position Offset Selection on page 25</i> . The display range is 0 - 65535 counts. Note: Counts = Encoder PPR x 4.	No Signal Output Available	Cnts	---Y--Y
U7-05	0664h	Sequence Step Sequence Step	Displays the active orientation offset parameter. See parameter P2-01 and <i>Orient Position Offset Selection on page 25</i> for more information. The display range is 0 - 4. 0: P2-02 1: P2-03 2: P2-04 3: P2-05 4: Memobus	No Signal Output Available	-	---Y--Y
U7-06	0665h	Serial Offset Serial Offset	This monitor reflects the data in Memobus register 0012h. <i>Refer to Orient Position Offset Selection on page 25</i> . The display range is 0 - 65535 counts.	No Signal Output Available	Cnts	---Y--Y

Table 11 MEMOBUS/Modbus Registers

Address	Description
0012h	Orient Offset When P2-01 = 2, this Memobus register defines the orientation offset from the marker pulse. The setting range is 0 - 65535. The data is not saved upon power loss. Register 0012h does not require the use of an Enter or Accept command. The written data is immediately active.

Table 12 Multi-Function Input Settings (H1-□□)

Setting	Description	Control Method/ Access Level
50	Mode Sw Disable Closed: All frequencies are V/f control. When open, the control mode switches from Closed Loop Vector control to V/f control according to the Control Mode Switchover Frequency S2-01. This multi-function input is only accepted while the inverter is stopped. The status of this multi-function input is dismissed during run.	---Y--N
80	Orient CMD Closed: Causes the drive to orient the motor to the current orientation position offset from the marker pulse. The motor orients in the direction of the run command. <i>Refer to Function Description on page 17</i> .	---Y--N
81	Orient CMD FWD Closed: Causes the drive to run in the forward direction and orient the motor to the current orientation position offset from the marker pulse. <i>Refer to Function Description on page 17</i> .	---Y--N

Setting	Description	Control Method/ Access Level
82	Orient CMD REV Closed: Causes the drive to run in the reverse direction and orient the motor to the current orientation position offset from the marker pulse. <i>Refer to Function Description on page 17.</i>	---Y--N
83	Sequential Reset Closed: Sets the active orientation offset parameter to P2-02 (sequence 0). This function is only active if P2-01 = 1.	---Y--N
84	Offset Sel 1 Orientation Position Offset Selection 1. See Section <i>Refer to Orient Position Offset Selection on page 25</i> and parameters P2-02, P2-03, P2-04 and P2-05.	---Y--N
85	Offset Sel 2 Orientation Position Offset Selection 2. <i>Refer to Orient Position Offset Selection on page 25</i> and parameters P2-02, P2-03, P2-04 and P2-05.	---Y--N
86	Gear Ratio Sel 1 Motor Gear Ratio Selection 1. <i>Refer to Configuration 2: Indirect Drive with Orientation Encoder on page 23</i> and parameters P2-06, P2-07, and P2-08.	---Y--N
87	Gear Ratio Sel 2 Motor Gear Ratio Selection 2. <i>Refer to Configuration 2: Indirect Drive with Orientation Encoder on page 23</i> and parameters P2-06, P2-07, and P2-08.	---Y--N

Table 13 Multi-Function Output Settings (H2-□□)

Setting	Description	Control Method/ Access Level
40	Orient Complete Closed: The machine is within the orient position window established by P1-05 and the P1-07 ORT Set Time has expired. Once this condition is met, the output remains closed as long as the machine is within the P1-06 window.	---Y--N
41	Home Position Closed: The active orientation position offset is P2-02 (sequence 0). This output is only active when P2-01 = 1 (Sequential Marker Offset Selection).	---Y--N

◆ Troubleshooting

Table 14 Faults

Fault Indication Digital Operator Display <Memobus>	Description	Cause	Countermeasures
Marker Pulse Detection Error CDEV Marker Det Error <3Ch>	<p>The drive monitors the number of A and B channel encoder pulses between each marker pulse (Z or C channel). There should be F1-01 (Encoder PPR) A and B channel pulses between each marker pulse. If the pulse count exceeds F1-01 x 8, the drive displays a CDEV fault and coasts to a stop.</p> <p>Note: If Orientation encoder parameter P1-10 = 1, parameter F1-31 sets Encoder PPR. If an Indirect Drive configuration is used, Orientation encoder PPR is multiplied by the active gear ratio.</p>	<p>This fault is displayed when the motor has gone two rotations without receiving a marker pulse from the motor encoder (Z or C channel). This could be caused by disconnected or malfunctioning hardware, or inappropriate parameter settings.</p> <p>This fault is only triggered while an orient digital input is activated and the frequency reference is less than the P1-01 Orient Speed.</p>	<ul style="list-style-type: none"> - Remove all run commands from the drive. Check the wiring of the encoder, especially the Z pulse. - Check for noise on the encoder feedback signals. - Check the F1-01/F1-31 parameter setting matches the encoder being used.

2 Spindle Orientation

Table 15 Errors

Alarm Indication Digital Operator Display <Memobus>	Description	Cause	Countermeasures
Orient Parameter Selection Error OPE12 Orient Param Err <0Ch>	<p>This Operator Programming Error occurs when spindle orient parameters are set in a way that may cause unintended operation.</p> <p>This error covers the following parameter settings:</p> <ol style="list-style-type: none"> 1. The CN5-B encoder is set as both the position and motor encoder. 2. The Orient Speed parameter P1-01 is set too close to Control Mode Switch Frequency S2-01 (S2-11 if Motor 2 is programmed). 3. Reverse Operation (b1-04) is disabled for orient applications. 4. Minimum Frequency (E1-09) is set too high. 5. Orient Encoder set for CN5-B but the PG option card is missing. 	<ol style="list-style-type: none"> 1. The drive is in Closed Loop Vector Control Mode (A1-02 = 3), digital input H1-0□ = 16h is programmed, Motor 2 Option Card Port Selection Parameter F1-30 = 1 (CN5-B), and Orientation Encoder Channel Selection Parameter P1-10 = 1 (CN5-B). 2. P1-01 + S2-02 is greater than S2-01. (Or P1-01 + S2-12 is greater than S2-1 if Motor 2 is selected.) 3. Parameter b1-04 = 1 and digital input H1-0□ = 80/81/82h. 4. Parameter E1-09 is greater than the P1-02 Creep Speed while the drive is configured for orient. 5. Orientation Encoder Card Selection Parameter P1-10 = 1 (CN5-B) and a PG-X3 or PG-B3 option card is not installed in CN5-B while digital input H1-0□ = 80/81/82h. 	<ol style="list-style-type: none"> 1. Remove CN5-B Encoder Conflict. <i>Refer to References on page 31.</i> <ol style="list-style-type: none"> a. Program the drive for V/f Control Mode (A1-02 = 0). b. De-program the digital input H1-0□ = 16h. c. Change Motor 2 Option Card Port Selection Parameter F1-30 = 0 (CN5-C). d. Change Orientation Encoder Channel Selection Parameter P1-10 = 0 (CN5-C). 2. Set P1-01 to at least S2-02 Hz less than S2-01, or set S2-01 = 0Hz. 3. Enable reverse operation (b1-04 = 0) or de-program orient digital inputs H1-0□ = 80/81/82h. 4. Set E1-09 less than the P1-02 value or de-program orient digital inputs H1-0□ = 80/81/82h. 5. Power down the drive and install a PG-X3 or PG-B3 option card into CN5-B, change the orientation encoder to be CN5-C (P1-10 = 0), or change digital input H1-0□ != 80/81/82h.

Table 16 Modified Errors

Alarm Indication Digital Operator Display <Memobus>	Description	Cause	Countermeasures
Control Mode Switchover Frequency Error OPE21 Switch Freq Err <0Ch>	<p>The permissible hardware frequency limit of PG option card is exceeded.</p>	<p>The S2-01 Control Mode Switchover frequency is too high for the encoder with PPR set in parameter F1-01 (F1-31 for encoders hooked up to option cards in port CN5-B).</p>	<p>Set the value of Control Mode Switchover Frequency S2-01 within the conditions below:</p> <p>PG-B3: $F1-01 \times S2-01 \times 2/E2-04 > 50 \text{ kHz}$</p> <p>PG-X3: $F1-01 \times S2-01 \times 2/E2-04 > 300 \text{ kHz}$</p>

◆ Function Description

The spindle orientation function begins when one of the orient digital inputs (80h, 81h, or 82h) outlined in *Table 12* is closed. These orient digital inputs can be broken into two modes: Orient from Run, and Orient from Stop. These two modes are discussed later in this section.

Orient only occurs when the drive is in Closed Loop Vector (CLV) control mode. This can be achieved by setting the P1-02 Creep Speed below the window established by the S2-01 Control Mode Switchover Frequency and the S2-02 Control mode Switchover Bandwidth. *Figure 2* shows how the drive returns to Closed Loop Vector operation once an orient is commanded.

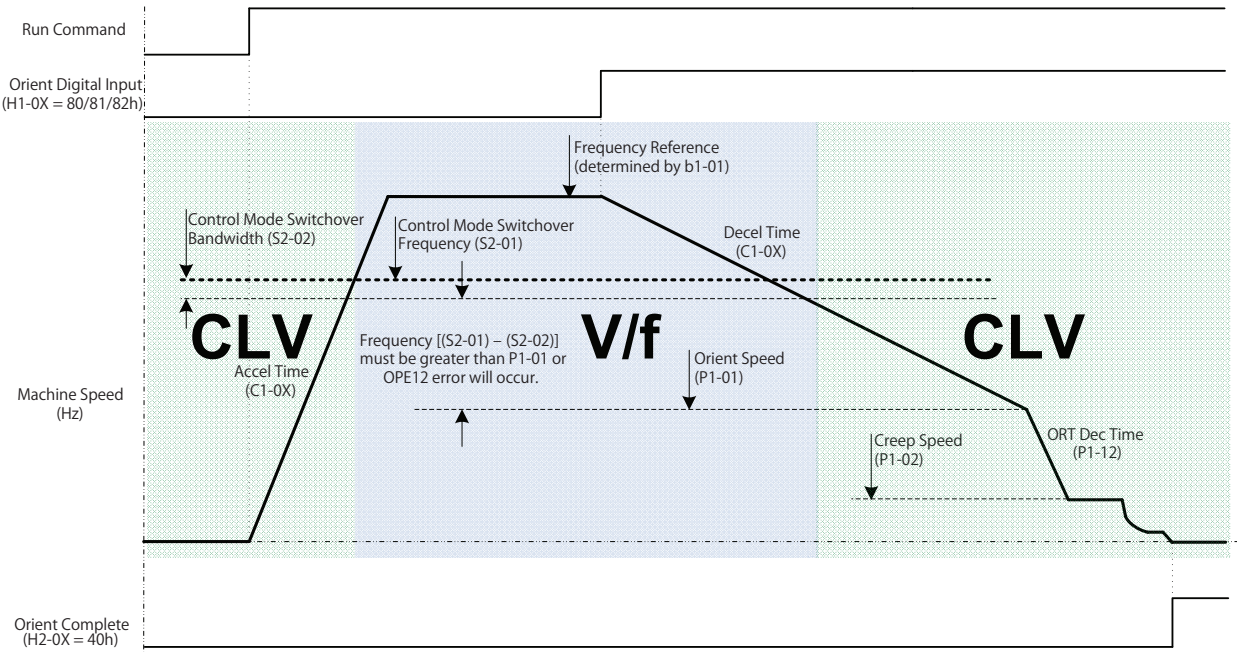

Figure 2 Orient Operation with High Frequency Switchover

2 Spindle Orientation

■ Orient from Run

An Orient from Run is initiated by closing one of the orient digital inputs (80h, 81h, or 82h) while the drive is running. These digital inputs command the drive to orient the spindle to the requested offset. In an orient from run, the drive soft starter status is used to determine the orient direction. If the soft starter output is zero (the drive is holding position), the orient direction is determined by the commanded run direction when an 80h Orient CMD is given, and by the orient digital inputs themselves when an 81h Orient FWD or 82h Orient REV is commanded. The run direction logic is outlined in [Figure 3](#).

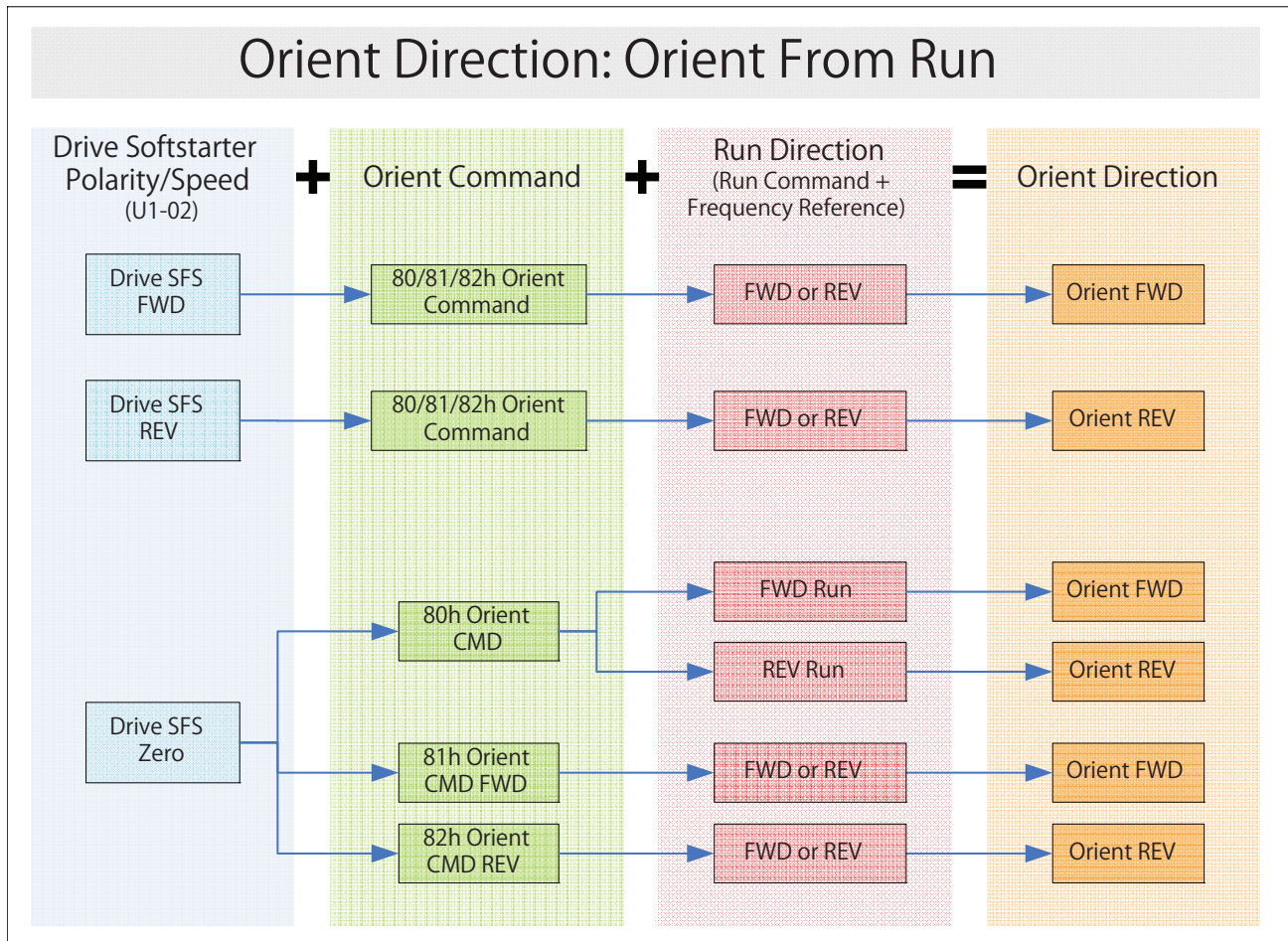

Figure 3 Orient Direction Determination

Both the run command and an orient digital input must be present for the drive to regulate and hold the desired position. The 80h Orient Command digital input is special such that if the run command is removed during orientation, the drive stops according to the b1-03 Stopping Method and orientation is not completed. Note, however, that the 81h Orient Command Forward and 82h Orient Command Reverse digital inputs provide their own run command to the drive, so removing the run command to the drive does not cancel the orient when using these orient digital inputs.

If the run command is present during orientation and all orientation digital inputs (80h, 81h, and 82h) are removed, the drive resumes normal operation at the current speed reference.

When multiple orient digital inputs are issued simultaneously, the function of the subsequent orient digital inputs are ignored. The orient command is cleared once all orientation digital inputs are opened.

[Figure 4](#) covers the Orient from Run deceleration profile after an orient digital input is activated. The figure is broken up into three areas. Area A includes deceleration to the P1-02 Creep Speed. Area B represents locating the marker.

Area C represents the final approach of the spindle once it has reached the desired offset. Each area is described in more detail in the following sections.

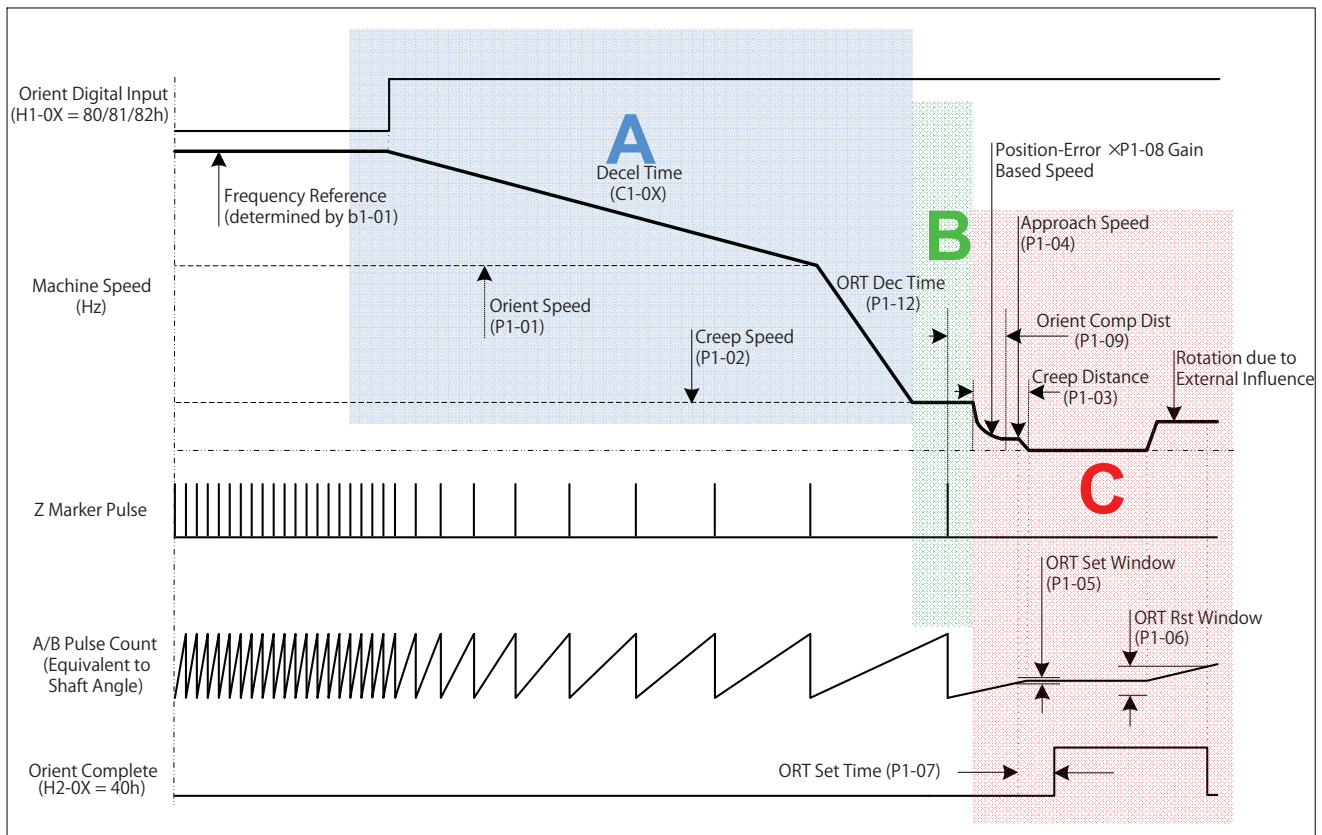

Figure 4 Orientation Deceleration Profile from Run

Area A: Deceleration

The drive decelerates using the C1-0□ deceleration time until it reaches the Orient Speed defined in parameter P1-01. At the P1-01 Orient Speed, the software checks the status of Orientation Deceleration Selection parameter P1-11 and Orientation Deceleration Time parameter P1-12 to determine the deceleration time used at frequencies below P1-01. If parameter P1-11 is enabled, deceleration time switches from C1-0□ to P1-12 as shown in [Figure 4](#) above. The drive ramps its current ASR P Gain to ASR P Gain 3 (P2-10) if Orientation ASR Enable parameter P2-09 is enabled.

Area B: Marker Location

The P1-02 Creep Speed is the speed that the drive will cruise at while determining the location of the marker pulse on the C/Z channel of the orientation encoder. The purpose of the Creep Speed is to provide a steady speed for reading the marker pulse which gives consistent and repeatable marker pulse location. Once the marker pulse has been found, the drive will disable s-curves and calculate the position error. The position error is calculated to be the distance between the current spindle orientation and the selected P2-02/03/04/05 marker offset. If the position error is less than the number of counts specified in Orientation Compensation Distance P1-09, the drive will add an additional rotation to allow the drive to come to a controlled stop once the drive enters position error-based control.

Area C: Position Error-Based Control

The drive enters position error-based control once the calculated position error is less than the P1-03 Creep Distance. Within the Creep Distance, the frequency reference is calculated using the product of the position error (in encoder counts) and the Positioning Proportional Gain as determined by Positioning Proportional Gain parameter P1-08. The frequency reference is upper limited to the P1-02 Creep Speed and lower limited to the P1-04 Approach Speed. The purpose of the Approach Speed is to decrease the time it takes to complete an orient by ignoring low frequency references until the drive reaches the P1-05 Orientation Complete Detection Set Window. If the P1-04 is programmed to be greater than the P1-02, the drive runs at the P1-04 speed while within the creep distance. Within the creep distance, the drive acceleration and deceleration times are also set to zero. This allows the drive to respond appropriately to the position error without being influenced by the C1-0□ accel/decel times.

2 Spindle Orientation

Once the position is maintained within the Complete Detection Set window P1-05 for the length of time defined by the ORT Set Time P1-07, the H2-0□ digital output programmed to Orient Complete (40h) is set and Zero Servo control is enabled. With Zero Servo control enabled, any remaining position error is resolved by the Zero Servo algorithm. Also, if Orientation ASR Enable parameter P2-09 is enabled, the P2-10 ASR Gain setting is ramped to the P2-12 (ASR P Gain 4) setting over the time specified by parameter P2-13 (ASR I Time 4).

Zero Servo Gain parameter b9-01 controls the responsiveness of the drive when external loads are applied. If an external influence forces the position of the spindle outside of the P1-06 Orientation Detection Complete Reset Window, the Orient Complete digital output is reset but the drive remains in Zero Servo Control. A detailed description of Orientation Complete Detection Set and Reset windows can be found in [Orientation Set/Reset Window on page 28](#).

Note: The position control algorithm requires control of the drive at frequencies well below 1 Hz. Therefore, drive parameters b1-05 and E1-09 should remain programmed to their default values.

■ Orient from Run: Frequency Reference below P1-02

If the drive is running at a frequency reference below P1-02 and an orient digital input is closed, the drive accelerates towards the P1-02 Creep Speed using the drive Acceleration Time C1-0□ until it finds the marker pulse. The drive ramps its current ASR P Gain to ASR P Gain 3 (P2-10) if Orientation ASR Enable parameter P2-09 is enabled. Once the marker pulse is found, s-curves are disabled and the position-error is calculated in the same fashion as the Orient from Run example discussed in the above section.

Note: If the drive has an active run command and a frequency reference of 0 Hz, the drive accelerates in the commanded run direction when an 80h Orient CMD is given. If an 81h Orient CMD FWD or 82h Orient CMD REV is given, the drive ignores the commanded run direction.

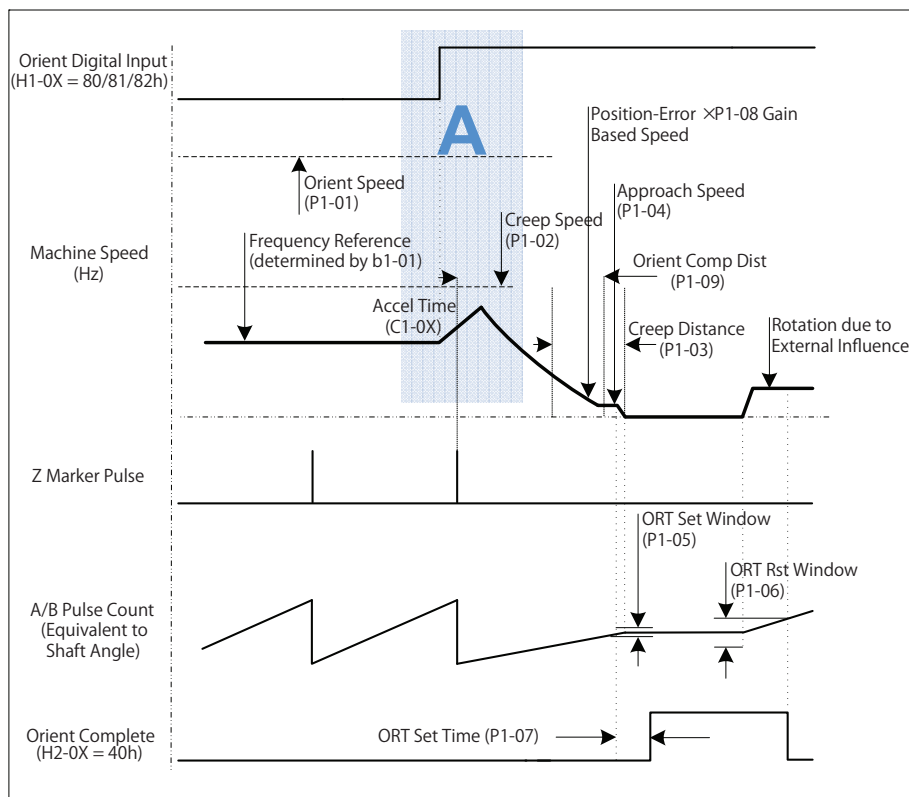

Figure 5 Orientation Profile from Below P1-02

■ Orient from Stop

An orient from stop is performed when the spindle is at rest, no RUN command is present, and one of the 81h Orient CMD FWD or 82h Orient CMD REV digital inputs is closed. Separate run commands are not required to perform an orient from stop, as the 81h and 82h digital inputs provide their own run command to the drive.

An Orient from Stop can also be performed when the 80h Orient Command is applied while the drive is at rest and the drive is then issued a run command.

Area A: Acceleration

If the spindle is stopped at a position outside of the Orient Complete Detection Set Window and the Orient CMD FWD (81h) is issued, the drive begins to run in the forward direction and accelerate to a speed determined by the product of the real-time position error and the Positioning Proportional Gain P1-08. This speed is limited to a maximum of the P1-02 Creep Speed as demonstrated in Area A of [Figure 6](#). If the spindle is to be oriented in the reverse direction, orient digital input 82h (Orient CMD REV) should be used.

If the spindle position is within the Orient Complete Detection Set Window, the drive orients as described in [Orientation Set/Reset Window on page 28](#).

Area B: Deceleration and Control

Area B shows how the position regulator determines the frequency reference during orient. The Positioning Proportional Gain parameter P1-08 adjusts the responsiveness of the position regulator. Unlike an Orient from run, the drive does not look for the marker pulse when performing an Orient from Stop because the marker position has already been determined (except during a power-up condition as described in [Orient from Stop - Find Marker on page 22](#)).

Note: Increasing Positioning Proportional Gain parameter P1-08 decreases the orient time when an orient from stop is performed (as represented by the dashed line machine speed curve as represented in [Figure 6](#)). Increasing this gain may also cause overshoot, if this happens, decrease P1-08 until the overshoot disappears. Raising the P1-02 Creep Speed decreases the orient time of an orient from stop.

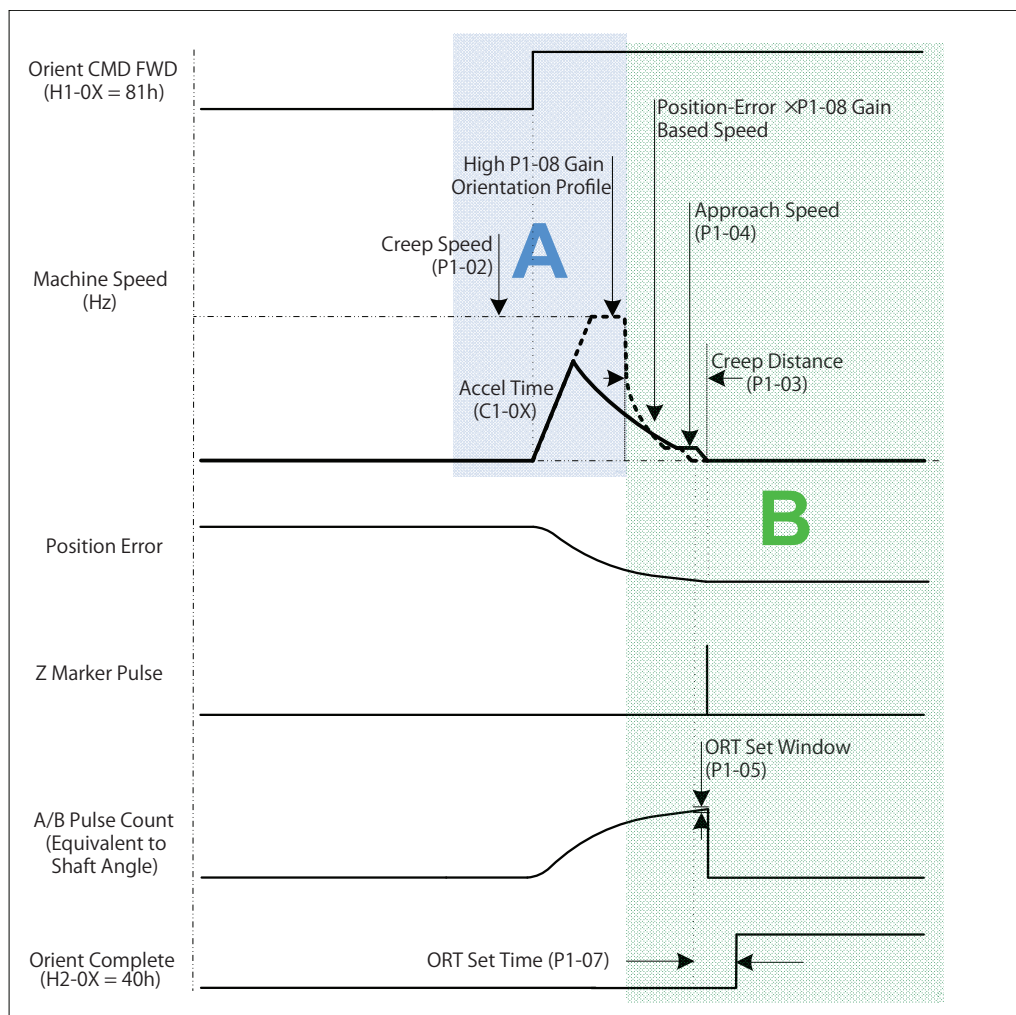

Figure 6 Orient Profile from Stop

Note: If an 81h Orient CMD FWD or 82h Orient CMD REV digital input is removed and reapplied while the Orient Complete output

2 Spindle Orientation

(40h) is active (the spindle remains within the P1-06 window) and the spindle is being commanded to its current offset, the drive immediately proceeds into final positioning regardless of the error direction.

■ Orient from Stop - Find Marker

When the drive is first powered up, the location of the marker pulse is not known. If the drive is commanded to perform an Orient from Stop immediately after power up, the drive will first look for the marker as shown in Area A of [Figure 7](#). Once the marker pulse is found, operation is identical to the Orient from Run example discussed in [Orient from Run on page 18](#).

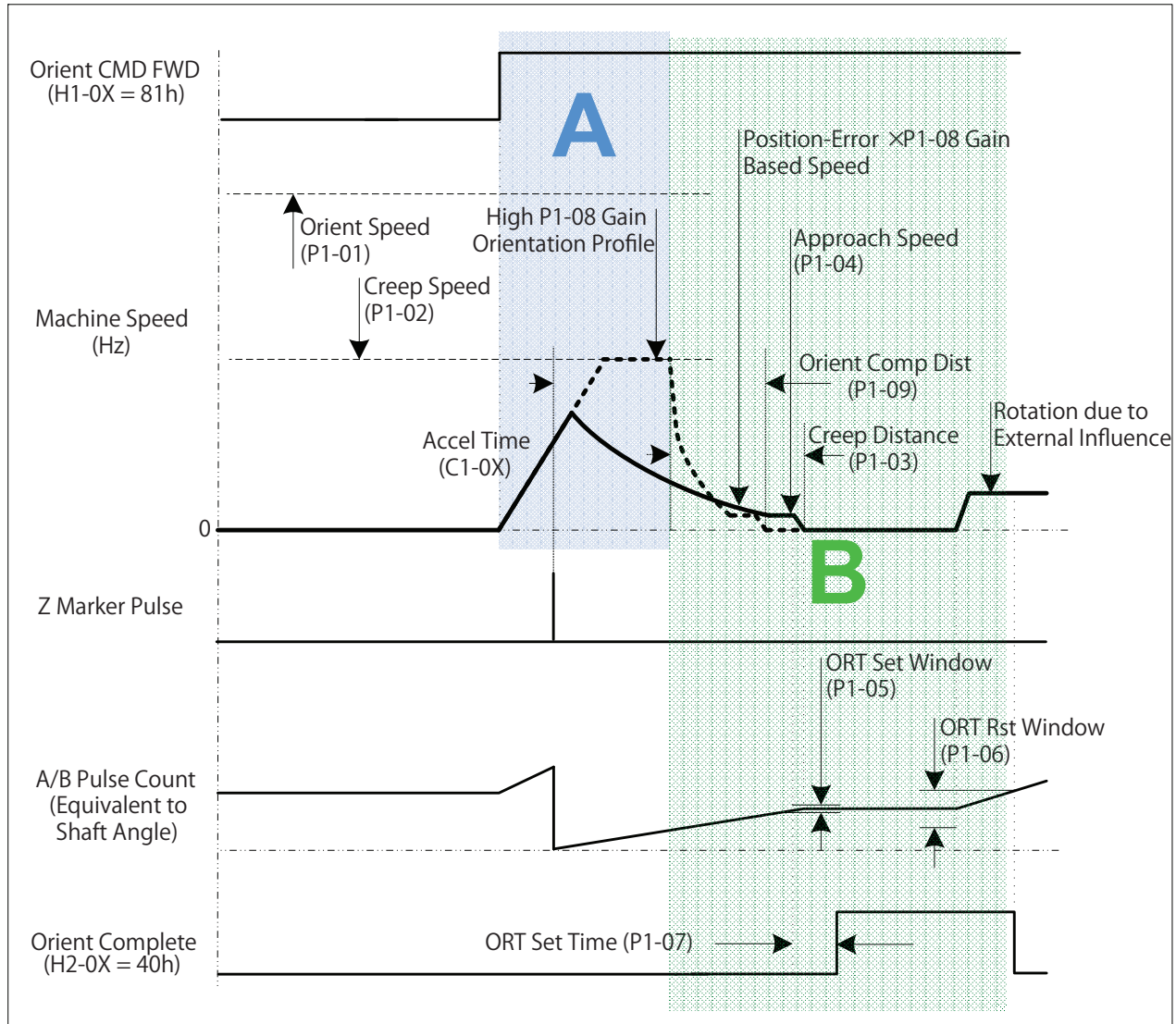

Figure 7 Orient from Stop Including Marker Pulse at P1-02

Application Configurations

Typical applications are as follows:

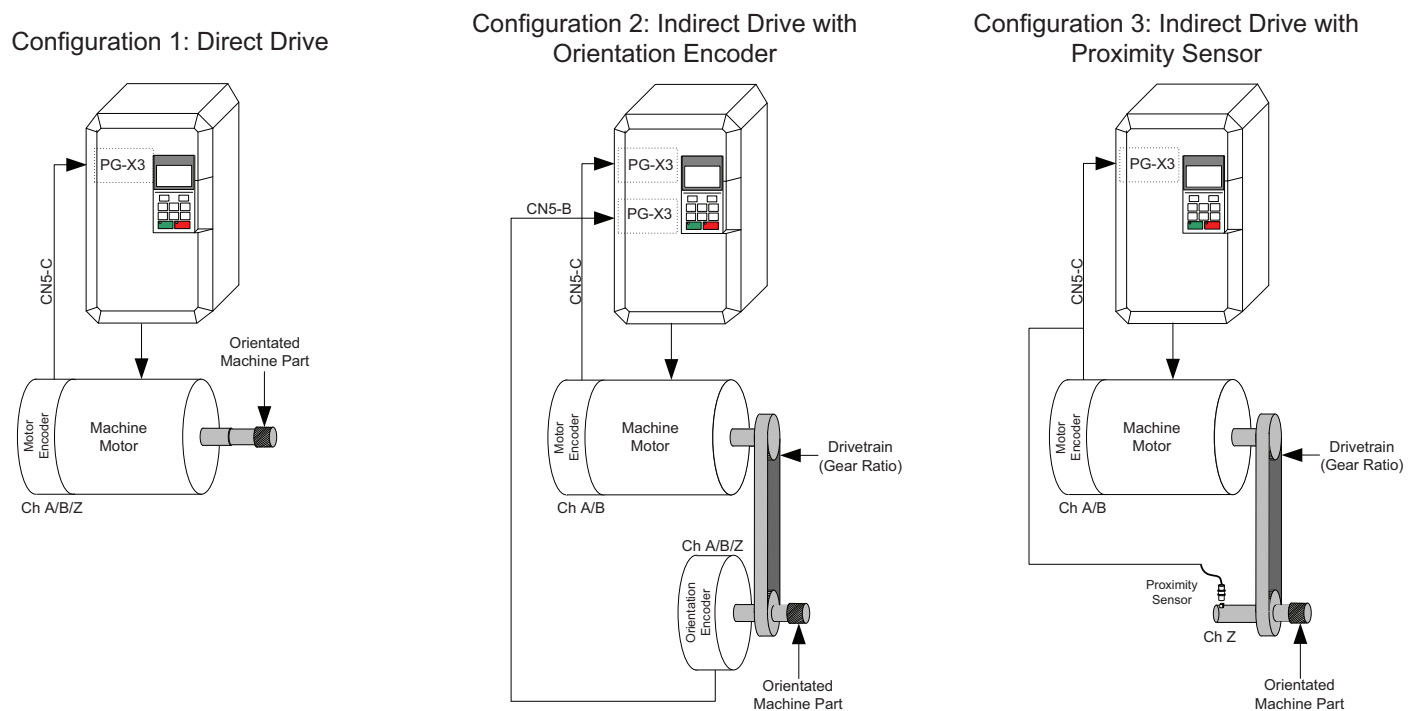

Figure 8 Application Configurations for Applicable Control Methods

Configuration 1: Direct Drive

This is a direct drive system where the encoder, motor and spindle shafts are directly coupled. This system can use the motor's encoder for orientation and closed loop vector control (A1-02 = 3) of the motor to provide the best performance. The orientation encoder must have a marker pulse (referred to as the Z or C pulse).

Configuration 2: Indirect Drive with Orientation Encoder

This is an indirect drive system where the motor and the spindle shaft are connected through a drive train. The orientation encoder is coupled to the spindle shaft which is used for spindle positioning, while the motor encoder is used for closed loop vector control.

Both encoders must have quadrature feedback (A and B channels with compliments). The orientation encoder must also have a marker pulse (referred to as the Z or C pulse).

Note: If the Orient encoder phasing is incorrect (A and B phases are swapped), the drive fails to orient. The symptom of incorrect orientation encoder phasing would be a drive that ramps down to the P1-02 creep speed but does not orient. If the orientation encoder is CN5-B, then changing PG 2 Rotation Selection Parameter F1-32 or swapping A/B encoder wires on the CN5-B option card should resolve the issue.

In this configuration, the gear ratio of the drive train must be expressed as an exact number of motor revolutions per revolution of the spindle. By default, the software is programmed with a gear ratio of 1.0000. If the motor and the proximity sensor are connected by a gear train, their ratio can be expressed within the range of 0.0400 to 2.5000. A ratio of 2.0000 means that there are two motor shaft revolutions for every revolution of the spindle (and every proximity sensor pulse). This gear ratio may be changed by modifying parameters P2-06, P2-07, and P2-08, and then selecting the gear ratio using Gear Ratio Select digital inputs 86h and 87h. If neither of the digital inputs 86h or 87h is programmed, P2-06 is the active gear ratio.

2 Spindle Orientation

Multi-Function Digital Input (H1-□□) Selection		Effective Parameter
87: Motor Ratio Selection 2	86: Motor Ratio Selection 1	
Open	Open	P2-06: Motor Gear Ratio 1
Open	Closed	P2-07: Motor Gear Ratio 2
Closed	Open	P2-08: Motor Gear Ratio 3
Closed	Closed	P2-06: Motor Gear Ratio 1

To prevent unintended operation, the motor ratio that is selected when an orient digital input is applied latches until the orient digital input is removed. If the state of the digital inputs 86h and 87h change during orientation, the new motor ratio is effective after all orient digital inputs are removed.

Note: This software does not fully support multiple motor selection using the multi-function digital input function Motor 2 Select (H1-□□ = 16). However, the software can be utilized for winding change applications by setting PG Option Card Port for Motor 2 Selection parameter F1-30 = 0 and Orientation Encoder Card Selection parameter P1-10 = 0. When using two PG-X3 cards, it is possible to run 2 different motors, **provided that they share the same orientation encoder** (the orientation encoder is always defined by P1-10 regardless of Motor 1/2 selection).

Configuration 3: Indirect Drive with Proximity Sensor

When the motor and the spindle are connected through a drive train and the spindle does not have its own encoder, a proximity sensor may be used. The proximity sensor configuration is enabled by setting Proximity Sensor Enable parameter P1-13 = 1. The proximity sensor is connected as an external marker pulse as described in [Encoder \(PG\) Option Card Configuration and Wiring on page 29](#). Parameter P1-15 (Proximity Sensor Pulse State) allows for configuration of both normally open and normally closed external marker pulses.

In this configuration (P1-13 = 1), the gear ratio of the drive train must be expressed as an exact number of motor revolutions per revolution of the spindle. This gear ratio may be changed by modifying parameters P2-06, P2-07, and P2-08, and then selecting the gear ratio using Gear Ratio Select digital inputs 86h and 87h as discussed in [Configuration 2: Indirect Drive with Orientation Encoder on page 23](#).

Proximity sensors measure the presence or absence of a target, and therefore the pulse width is often much larger than an encoder Z channel, as indicated in [Figure 9](#). Since the PG-X3 option card interprets the marker pulse as the rising edge of the signal on the Z channel, the width of the marker pulse has a significant effect on the positioning accuracy in applications which require orientation from forward and reverse operation.

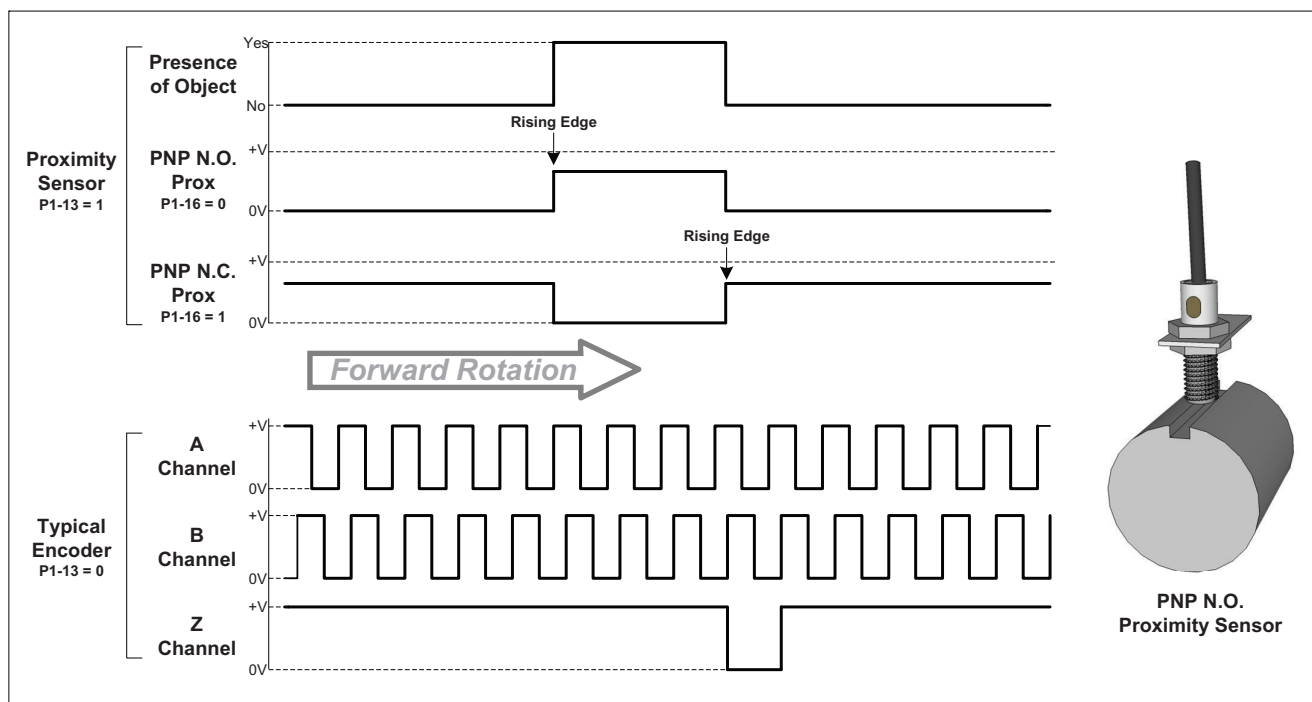

Figure 9 Comparison of Encoder and Proximity Sensor Marker Pulses

Proximity Sensor Pulse Width parameter P1-14 applies an offset to the proximity sensor pulse when the spindle is commanded to orient in the reverse direction. With parameter P1-14 set to 0 counts and a Marker Offset P2-02 = 0, the proximity sensor orients to opposite sides of the target when orienting from the forward and reverse directions. When P1-14 is set to the width of the target in encoder counts, the pulse width is applied in a way such that the spindle always orients to the side of the target which provides a rising edge when the spindle is turned in the forward direction.

Proximity sensor pulse width can be measured in counts by slowly turning the spindle and observing the elapsed counts on the U7-02 (Distance from Marker) monitor between the rising and falling edges of the sensor over the target. Some proximity sensors have an LED indicator to indicate the presence or absence of a target. If this is not present; the output of the proximity sensor can be viewed on an oscilloscope or measured using a multimeter. On applications requiring higher precision of orientation, the elapsed counts can be measured by simultaneously monitoring the A/B/Z channels of the encoder and proximity sensor and observing the elapsed counts during the period in which the marker pulse is sensed.

■ Orient Position Offset Selection

By default, the software is programmed with an offset of 0 counts from the marker pulse. This means that the spindle aligns itself to the marker pulse every time an orient is commanded. The drive may be oriented to another position by setting Marker Offset Selection parameter P2-01 to one of three selections outlined below.

The desired offsets must be programmed into marker offset parameters P2-02 through P2-05 or set using the Memobus register 0012h. Offsets which are specified as greater than one revolution are normalized to the encoder PPR x 4. If the offset values are not known, they can be found by rotating the spindle by hand. To find an offset value after powering up the drive, rotate the motor shaft until the orientation encoder axis turns for 1 rotation (360 deg), or until the drive recognizes the marker pulse. The drive indicates that the marker pulse is found once monitors U7-02 (Distance from Marker) and U7-03 (Distance from Offset) stop flashing “Looking for C/Z”. Rotate the machine to the desired position by hand or by the using the run inputs. Read the marker offset value of U7-02 and enter the value in one of the parameters P2-02 through P2-05 or the Memobus register.

P2-01 = 0, Digital Input Selection

This method uses the Offset Selection digital inputs 84h and 85h to determine the orient offset based on parameters P2-02, P2-03, P2-04, and P2-05. When no digital input is programmed or selected, P2-02 is used as the offset.

Multi-Function Digital Input (H1-□□) Selection		Effective Parameter	U7-05 Seq Step
85: Offset Selection 2	84: Offset Selection 1		
Open	Open	P2-02: Marker Offset 1	0
Open	Closed	P2-03: Marker Offset 2	1
Closed	Open	P2-04: Marker Offset 3	2
Closed	Closed	P2-05: Marker Offset 4	3

Note: Offset Selection digital inputs 84h and 85h are only effective while Marker Offset Selection parameter P2-01 = 0.

P2-01 = 1, Sequential Selection

This method rotates through the offset values specified in parameters P2-02, P2-03, P2-04, and P2-05 each time an orient is commanded. If the drive power is reset, the offset is re-initialized to P2-02.

Figure 10 demonstrates operation of the sequential offset mode and the Home Position digital output 41h. The Home Position digital output is functional only when parameter P2-01 is programmed to sequential selection. When the drive powers up and the first orient digital input is closed, the drive sets the 41h Home Position digital output and orient to the P2-02 offset. When the orient digital input is removed, the Home Position digital output is opened. The drive orients to the P2-03, P2-04 and P2-05 offsets when subsequent orient are commanded. When the orient digital input is removed after the P2-05 offset, the offset returns to P2-02.

When an orient digital input is activated, the drive chooses the orient offset position. This position remains in effect until all orient digital inputs are removed. If the state of the orient position offset digital inputs changes during orientation, the selection is not active until the orient digital inputs are removed. One additional digital input is available only during sequential selection:

2 Spindle Orientation

• Sequential Reset (83h)

When closed, this parameter sets the active orientation offset to the value specified in Marker Offset 1 parameter P2-02.

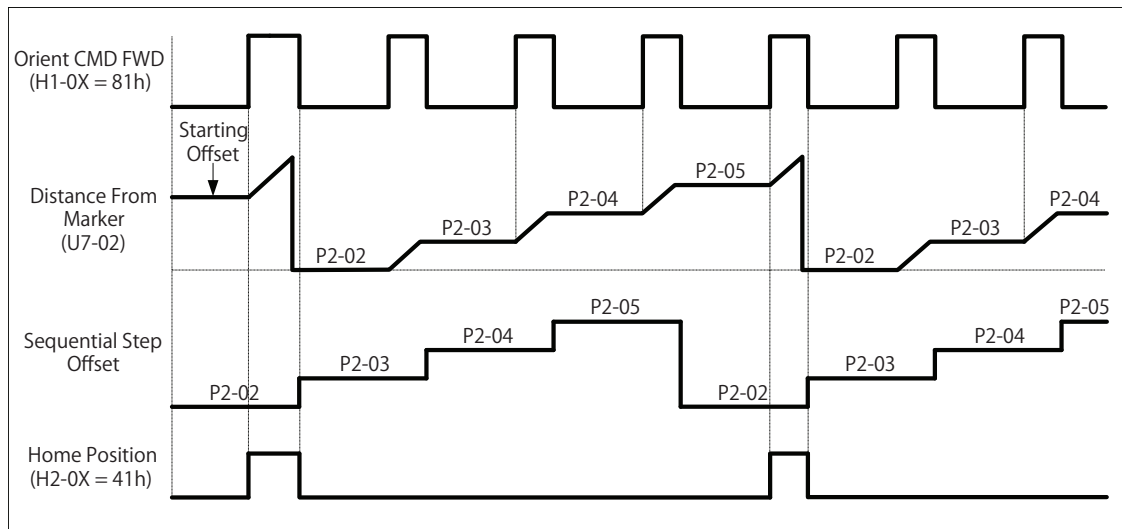

Figure 10 Operation of Sequential Orientation Feature

P2-01 = 2, Memobus COM Selection

This method uses the network communication offset (Memobus Register 0012h) as the offset from the marker pulse. When this setting is selected, parameters P2-02, P2-03, P2-04, and P2-05 are ignored. If the drive power is cycled, this register is reset to 0 counts.

An orient offset written to this register is displayed in monitor U7-06. If a write is performed to the Memobus register while an orient digital input is active, the value (and the U7-06 monitor) is not effective until the Orient Digital Input (80h, 81h, or 82h) is released.

■ Drive Monitors

This software has five monitors to aid in the setup and operation of the spindle orient system.

U7-02: Distance From Marker

This monitor displays the number of counts the orientation encoder is past the marker pulse (relative to the direction of travel). The monitor counts from 0 up to the number of $(F1-01 \times 4)$ encoder counts if CN5-C is the orientation encoder card, or the number of $(F1-31 \times 4)$ encoder counts if the orientation encoder card is CN5-B. Offsets which are specified as greater than one revolution are normalized to the encoder PPR.

When power to the drive is reset, this monitor is reset to 0. Since the orientation of the spindle is unknown while the drive is without power, upon power up the monitor alternates “Dist from Marker” / “Looking for C/Z” until the drive finds the first marker pulse. Once the marker pulse is found, the monitor resets to 0 once again, and the “Looking for C/Z” message clears.

When the drive exceeds the S2-01 Control Mode Switch Frequency (S2-11 if Motor 2 is selected), the encoder PPR may exceed the input frequency limit of the PG-X3/PG-B3 Encoder (PG) Feedback Card. Therefore, this monitor ceases to update when the frequency reference is above S2-01. The monitor alternates the text “Dist from Marker” / “PG Freq Limit” until the drive frequency is less than S2-01 and the marker pulse is located.

U7-03: Distance from Offset

This monitor displays the number of counts the orientation encoder is past the current offset (relative to forward rotation). The current offset value is latched at the rising edge of an orient digital input (as displayed in monitor U7-04). The monitor counts from 0 up to the number of $(F1-01 \times 4)$ encoder counts if CN5-C is the orientation encoder card, or the number of $(F1-31 \times 4)$ encoder counts if the orientation encoder card is CN5-B. Offsets which are specified as greater than one revolution are normalized to the encoder PPR.

When power to the drive is reset, this monitor is reset to 0. Since the orientation of the spindle is unknown while the drive is without power, upon power up the monitor alternates “Dist from Offset” / “Looking for C/Z” until the drive finds the first marker pulse. Once the marker pulse is found, the monitor is reset to 0 once again, and the “Looking for C/Z” message clears.

When the drive exceeds the S2-01 Control Mode Switch Frequency (S2-11 if Motor 2 is selected), the encoder PPR may exceed the input frequency limit of the PG-X3/PG-B3 Encoder (PG) Feedback Card. Therefore, this monitor ceases to update when the frequency reference is above S2-01. The monitor alternates the text “Dist from Offset” / “PG Freq Limit” until the drive frequency is less than S2-01 and the marker pulse is located.

U7-04: Commanded Offset

This monitor displays the current marker offset position. Each time an orient is commanded, this monitor is updated with the value of the current marker offset.

If Marker Offset Selection parameter P2-01=0, the drive is in Digital Input Select mode, and monitor U7-04 is updated with the offset count corresponding to the current state of the digital input(s) at the time when a valid orient digital input is activated. Refer to [Orient Position Offset Selection on page 25](#) for the digital input states.

If Marker Offset Selection parameter P2-01=1, the drive is in Sequential Select mode, and the monitor displays the next orient offset.

If Marker Offset Selection parameter P2-01=2, the drive is in Memobus Communication Selection mode, and the monitor displays the count value currently in Memobus register 0012h.

U7-05: Sequence Step

This monitor displays the range 0 to 4 which corresponds to the parameters P2-02, P2-03, P2-04, and P2-05 and the Memobus register 0012h. The value corresponds to the offset to which the drive orients when the orient digital input is activated.

If Marker Offset Selection parameter P2-01=0, the drive is in digital input Select mode, and monitor U7-05 is updated with the value corresponding to the current state of the digital input(s) at the time when a valid orient digital input is activated. [Orient Position Offset Selection on page 25](#) for the digital input states.

If Marker Offset Selection parameter P2-01=1, the drive is in Sequential Select mode, and the monitor displays the next orient offset. This value is reset every time an orient digital input is activated.

If Marker Offset Selection parameter P2-01=2, the drive is in Memobus Communication Selection mode, and the monitor displays the value 4. The U7-04 monitor displays the count value currently in Memobus register 0012h.

U7-06: Serial Offset

This monitor displays the orientation position offset specified by the Memobus register 0012h. Since the Memobus register is not saved upon power loss, this monitor is re-initialized to 0 counts upon power up.

Note: This monitor reflects the value last written to the Memobus register. Since the Memobus register offset value is latched when an orient digital input is activated, the value displayed on the monitor may not match the orient position if the Memobus register is rewritten during orient.

■ Orient ASR P Gain and I Time

The Spindle Orient function has the ability to change the ASR parameters during orient. This feature is enabled by the Orientation ASR Enable Parameter P2-09. When P2-09 is set to enabled, the drive switches from the active C5-0□ ASR P Gain and ASR I Time to the values programmed in P2-10 (ASR P Gain 3) and P2-11 (ASR I Time 3).

To prevent any sudden change in operation at P1-01, the ASR P Gain is ramped from the current C5-0□ level to the P2-10 level over the time period specified by the P2-11 ASR I Time. The P2-11 ASR I Time is switched immediately upon reaching the P1-01 Orient Speed. Once the drive enters Zero Servo Control, the P2-11 ASR gain setting is ramped to the P2-12 (ASR P Gain 4) setting over the time specified by parameter P2-13 (ASR I Time 4).

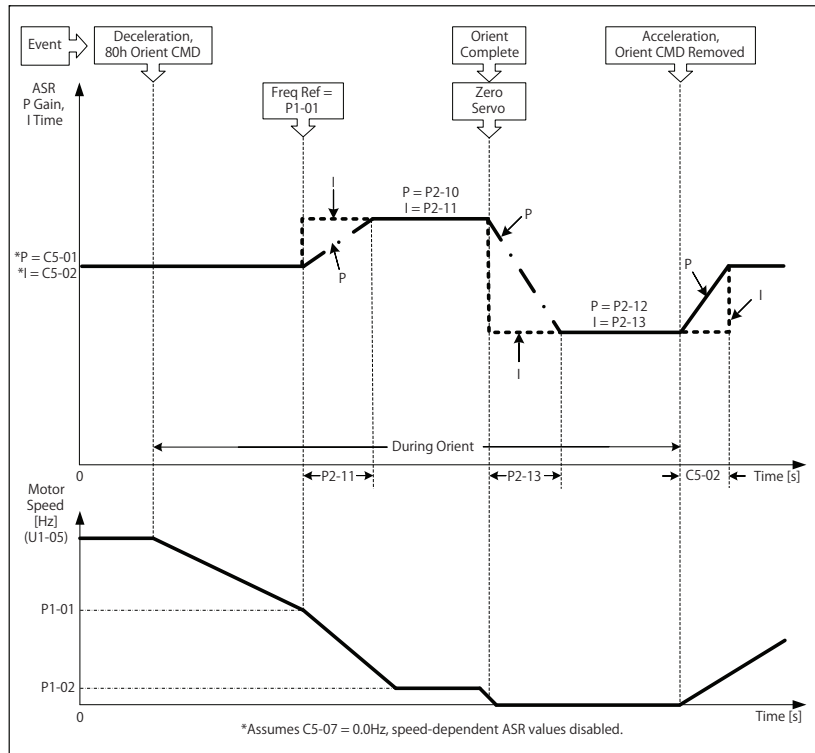

Figure 11 ASR Gain/Time Change During Orient

■ Orientation Set/Reset Window

Figure 12 visualizes the Orientation windows P1-05 and P1-06. The motor enters the dark grey Orient Set Window once the difference between the current position and the desired Marker Offset is less than P1-05 counts. If the current position is maintained within the dark grey window for longer than the Orientation Set Time P1-07, the multi-function digital output H2-□□ set to 40h will go high. This output remains high as long as the shaft maintains its position within \pm P1-06 counts of the Marker Offset, which is the light grey Orientation Reset Window in Figure 12.

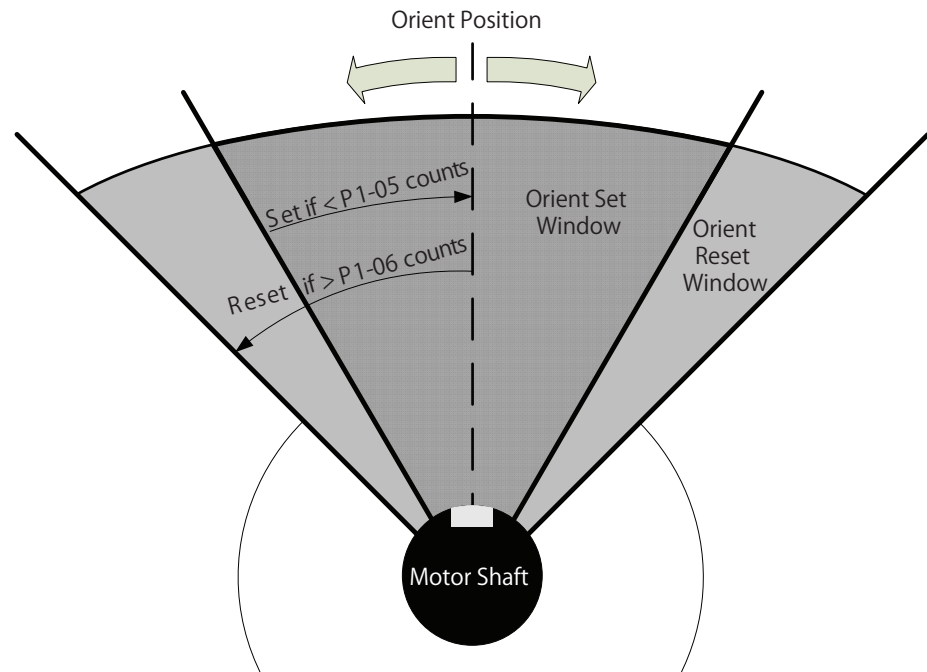

Figure 12 Orientation Set and Reset Windows

Important Notes Regarding the Orient Window Functionality:

- If the P1-05 orient detection set window is set greater than the P1-06 reset window, the software limits P1-05 to the P1-06 setting. This is required for the Orient Complete digital output function to work properly.
- The Orient Complete digital output is only active during orient when the commanded frequency reference is below the P1-02 Creep Speed.
- The P1-07 ORT Set Time does not apply to the Orient Reset Window. If the actual position deviates from the orientation position by more than P1-06 counts, the Orient Complete digital output opens. The P1-07 timer is reset and the same ORT Set Time applies every time the spindle re-enters the Orient Set Window.
- If the drive is not running when an orient digital input is removed and reapplied while the drive is within the P1-06 window, the drive resumes position control within the orientation reset window so long as the commanded position offset is not changed.

Encoder (PG) Option Card Configuration and Wiring

The PG-X3 or PG-B3 Installation Manual should be used to determine the Encoder (PG) Feedback card(s) needed. All encoders must have quadrature feedback (A and B channels with compliments). The orientation encoder must also have a marker pulse (referred to as the Z or C pulse). If not, an external sensor must be used to locate the marker position.

The PG-X3 Encoder Feedback card requires a line driver type circuit for the marker (Z/C pulse) input. **Figure 13** shows an example of how a +12 Vdc current sinking (open collector NPN) switch can be used to trigger the marker pulse input of the encoder feedback card in situations where the application encoder does not have a Z/C channel. An external power supply may be required. For best noise immunity, locate the resistor network at the sensor, not at the encoder feedback card. Please note that the sensor must be able to handle at least 22 mA of current draw. For exact application wiring, consult Yaskawa Application Engineering with the exact sensor specifications.

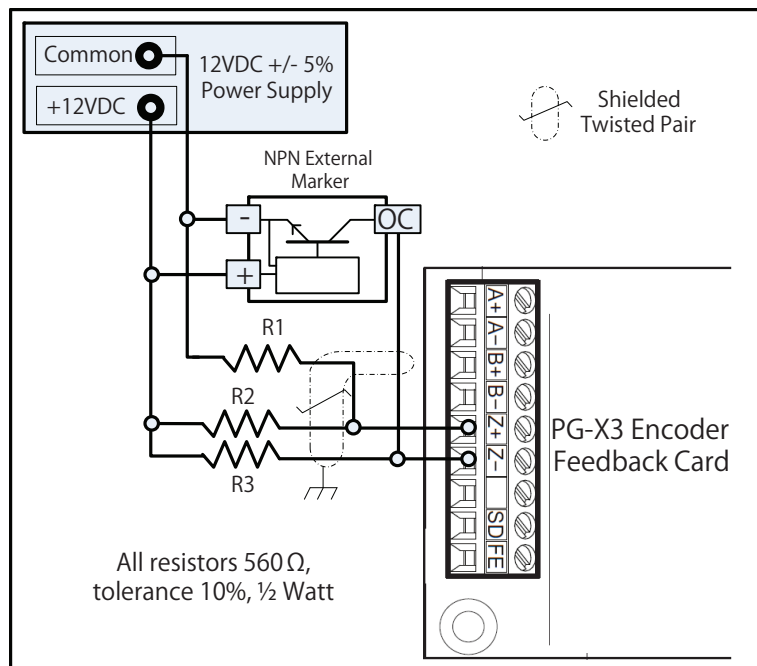

Figure 13 External Marker Pulse Wiring Diagram: NPN

2 Spindle Orientation

Figure 14 is an example of how a +12 Vdc current sourcing (open collector PNP) switch can be used to trigger the marker pulse input.

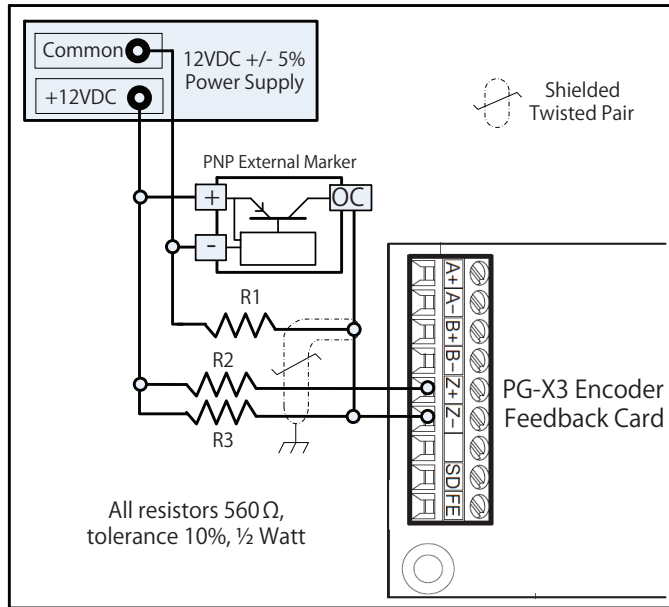

Figure 14 External Marker Pulse Wiring Diagram: PNP

■ Drive Wiring Examples

The examples in **Figure 15** are typical wiring diagrams for the direct and indirect positioning methods discussed in *Application Configurations on page 23*.

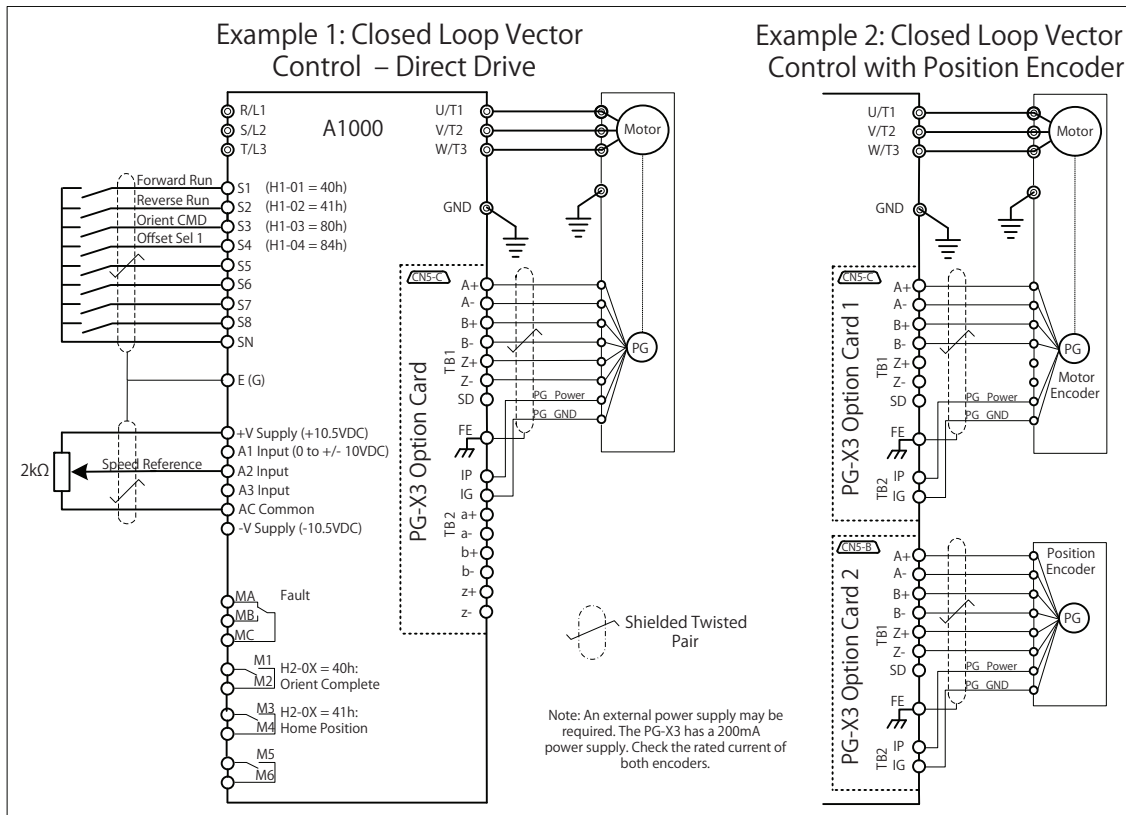

Figure 15 Wiring of Drive for Application Examples

◆ References

Table 17 Valid Configurations of Motor and Orientation Encoders

Encoder Channel Parameter Setting		Motor 1/2 (H1-0□ =16h)	Encoder Used For:		Valid Config.	Comment
P1-10	F1-30		Closed Loop Control	Orientation		
CN5-C	CN5-C	Motor 1	CN5-C	CN5-C	Yes	-
CN5-B	CN5-B	Motor 1	CN5-B	CN5-C	Yes*	*OPE12 occurs if H1-0□ programmed to 16h (Motor 2 Select)
CN5-C	CN5-B	Motor 1	CN5-C	CN5-C	Yes	-
CN5-B	CN5-C	Motor 1	CN5-C	CN5-B	Yes	Motor and Orientation Encoder PPR must match.
CN5-C	CN5-C	Motor 2	CN5-C	CN5-C	Yes	-
CN5-B	CN5-B	Motor 2	-	-	No	OPE12: Motor and Orientation Encoder conflict.
CN5-C	CN5-B	Motor 2	CN5-B	CN5-C	Yes	Motor and Orientation Encoder PPR must match.
CN5-B	CN5-C	Motor 2	CN5-C	CN5-B	Yes	Motor and Orientation Encoder PPR must match.

Chinese language support is added to certain parameters and functions:

Table 18 Parameter Chinese Display Text

Parameter No.	English Display Text	Chinese Display Text
P	Spindle Orient	主轴定位
P1	Orient Settings	定位设置
P1-01	Orient Speed	定位速度
P1-02	Creep Speed	爬行速度
P1-03	Creep Distance	爬行距离
P1-04	Approach Speed	临近速度
P1-05	ORT Set Window	定位完了设置视窗
P1-06	ORT Rst Window	定位完了复位视窗
P1-07	ORT Set Time	定位完了设定时间
P1-08	Pos P Gain	位置控制比例增益
P1-09	Orient Comp Dist	定位补偿距离
P1-10	ORT Enc Select 0: CN5-C 1: CN5-B	定位 PG 卡选择 0: CN5-C 1: CN5-B
P1-11	ORT Dec Sel 0: Disabled 1: Enabled	定位减速选择
P1-12	ORT Dec Time	定位减速时间
P1-13	Prox Sens Enable	距离传感器选择
P1-14	Prox Pulse Width	传感器脉冲幅度
P1-15	Prox Pulse State 0: Normally Open 1: Normally Closed	距离传感器状态 0: 常开 1: 常闭
P2	Offset & Gear	偏置和齿轮比
P2-01	MarkerOffset Sel 0: Digital Input 1: Sequential 2: Modbus COM	零位脉冲偏置选择 0: 数字输入 1: 顺控选择 2: modbus 通信
P2-02	Marker Offset 1	零位脉冲偏置 1
P2-03	Marker Offset 2	零位脉冲偏置 2

2 Spindle Orientation

Parameter No.	English Display Text	Chinese Display Text
P2-04	Marker Offset 3	零位脉冲偏置 3
P2-05	Marker Offset 4	零位脉冲偏置 4
P2-06	Motor Ratio 1	电机齿轮比 1
P2-07	Motor Ratio 2	电机齿轮比 2
P2-08	Motor Ratio 3	电机齿轮比 3
P2-09	ORT ASR Enable 0: Disabled 1: Enabled	定位 ASR 选择
P2-10	ASR P Gain 3	ASR 比例增益 3
P2-11	ASR I Time 3	ASR 积分时间 3
P2-12	ASR P Gain 4	ASR 比例增益 4
P2-13	ASR I Time 4	ASR 积分时间 4
S	High Frequency	高频
S1	HighFreq Control	高频控制
S1-01	OnDelay Comp Sel 0: Disabled 1: Enabled	延迟补偿选择 0: 无效 1: 有效
S1-03	Extend I Sample 0: Disabled 1: Enabled	扩展电流采样模式 0: 无效 1: 有效
S2	Ctrl Mode Switch	控制模式切换
S2-01	HF SwOver Freq	控制模式切换频率
S2-02	HF CtrlMode SwBW	控制模式切换频幅
S2-05	HF SlipComp Gain	滑差补偿增益
S2-06	HF SlipComp Time	滑差补偿延迟时间
S2-07	HF SlipComp Lim	滑差补偿极限
S2-08	HF SlipCompRegen 0: Disabled 1: Above 6 Hz 2: Lowst possbl spd	再生滑差补偿 0: 再生滑差补偿无效 1: 有效 6Hz 以上 2: 有效 全范围
S2-11	HF SwOver Freq 2	模式切换频率 2
S2-12	HF CtrlModeSwBW2	模式切换频幅 2
S2-15	HF SlipCompGain2	滑差补偿增益 2
S2-16	HF SlipCompTime2	滑差补偿延迟 2
S2-17	HF SlipComp Lim2	滑差补偿极限 2
S2-18	HF SlipCompRgn 2 0: Disabled 1: Above 6 Hz 2: Lowst possbl spd	再生滑差补偿 2 0: 再生滑差补偿无效 1: 有效 6Hz 以上 2: 有效 全范围

Table 19 Monitor Chinese Display Text

Monitor No.	English Display Text	Chinese Display Text
U7	Spindle Orient	主轴定位监视
U7-02	Dist From Marker	零位脉冲偏移距离
U7-03	Dist From Offset	零位脉冲偏置距离
U7-02/03 Alternate	Looking for C/Z	搜索零位脉冲
U7-02/03 Alternate	PG Freq Limit	编码器频率限制
U7-04	Commanded Offset	指令偏置

Monitor No.	English Display Text	Chinese Display Text
U7-05	Sequence Step	顺控步骤
U7-06	Serial Offset	串行偏置

Table 20 Multi-Function Input Chinese Text

Setting	English Display Text	Chinese Display
50h	Mode Switch Prev	控制模式切换选择
80h	Orient CMD	定位指令
81h	Orient CMD FWD	正转定位指令
82h	Orient CMD REV	反转定位指令
83h	Sequential Reset	顺控复位
84h	Offset Sel 1	零位偏置选择 1
85h	Offset Sel 2	零位偏置选择 2
86h	Gear Ratio Sel 1	电机齿轮比选择 1
87h	Gear Ratio Sel 2	电机齿轮比选择 2

Table 21 Multi-Function Output Chinese Text

Setting	English Display Text	Chinese Display Text
40h	Orient Complete	定位完了
41h	Home Position	原点位置

Table 22 Fault and Alarm Chinese Text

Fault or Alarm	English Display Text	Chinese Display Text
CDEV	Marker Det Error	零位脉冲检测错误
OPE12	Orient Param Err	定位参数错误
OPE21	Switch Freq Err	切换频率错误

3 Revision History

3 Revision History

The revision dates and the numbers of the revised manuals appear on the bottom of the back cover.

MANUAL NO. TM.A1000SW.063

Published in U.S.A. September 2011 11-6 
└─ Date of publication └─ Date of original publication └─ Revision number

Date of Publication	Revision Number	Software Number	Revised Content
August 2021	2	VSA91009x	Updated firmware number for reduced maximum frequency.
November 2011	1	-	Revised pg. 19, Area B: Marker Location contents.
September 2011	-	VSA910090	First release

YASKAWA AC Drive - A1000

Spindle Orientation

Custom Software Supplement

YASKAWA AMERICA, INC.

2121 Norman Drive South, Waukegan, IL 60085, U.S.A.
Phone: (800) YASKAWA (927-5292) or 1-847-887-7000 Fax: 1-847-887-7310
<http://www.yaskawa.com>

DRIVE CENTER (INVERTER PLANT)

2-13-1, Nishimiyaichi, Yukuhashi, Fukuoka, 824-8511, Japan
Phone: 81-930-25-3844 Fax: 81-930-25-4369
<http://www.yaskawa.co.jp>

YASKAWA ELECTRIC CORPORATION

New Pier Takeshiba South Tower, 1-16-1, Kaigan, Minatoku, Tokyo, 105-6891, Japan
Phone: 81-3-5402-4502 Fax: 81-3-5402-4580
<http://www.yaskawa.co.jp>

YASKAWA ELÉTRICO DO BRASIL LTDA.

Avenda Fagundes Filho, 620 Bairro Saude, São Paulo, SP04304-000, Brasil
Phone: 55-11-3585-1100 Fax: 55-11-5581-8795
<http://www.yaskawa.com.br>

YASKAWA EUROPE GmbH

Hauptstrasse 185, 65760 Eschborn, Germany
Phone: 49-6196-569-300 Fax: 49-6196-569-398
<http://www.yaskawa.eu.com>

YASKAWA ELECTRIC UK LTD.

1 Hunt Hill Orchardton Woods, Cumbernauld, G68 9LF, United Kingdom
Phone: 44-1236-735000 Fax: 44-1236-458182
<http://www.yaskawa.co.uk>

YASKAWA ELECTRIC KOREA CORPORATION

7F, Doore Bldg. 24, Yeoido-dong, Yeongdungpo-gu, Seoul, 150-877, Korea
Phone: 82-2-784-7844 Fax: 82-2-784-8495
<http://www.yaskawa.co.kr>

YASKAWA ELECTRIC (SINGAPORE) PTE. LTD.

151 Lorong Chuan, #04-01, New Tech Park, 556741, Singapore
Phone: 65-6282-3003 Fax: 65-6289-3003
<http://www.yaskawa.com.sg>

YASKAWA ELECTRIC (SHANGHAI) CO., LTD.

No. 18 Xizang Zhong Road, 17F, Harbour Ring Plaza, Shanghai, 200001, China
Phone: 86-21-5385-2200 Fax: 86-21-5385-3299
<http://www.yaskawa.com.cn>

YASKAWA ELECTRIC (SHANGHAI) CO., LTD. BEIJING OFFICE

Room 1011, Tower W3 Oriental Plaza, No. 1 East Chang An Ave.,
Dong Cheng District, Beijing, 100738, China
Phone: 86-10-8518-4086 Fax: 86-10-8518-4082

YASKAWA ELECTRIC TAIWAN CORPORATION

9F, 16, Nanking E. Rd., Sec. 3, Taipei, 104, Taiwan
Phone: 886-2-2502-5003 Fax: 886-2-2505-1280

YASKAWA

YASKAWA AMERICA, INC.

In the event that the end user of this product is to be the military and said product is to be employed in any weapons systems or the manufacture thereof, the export will fall under the relevant regulations as stipulated in the Foreign Exchange and Foreign Trade Regulations. Therefore, be sure to follow all procedures and submit all relevant documentation according to any and all rules, regulations and laws that may apply.

Specifications are subject to change without notice for ongoing product modifications and improvements.

© 2011 YASKAWA AMERICA, INC. All rights reserved.



MANUAL NO. TM.A1000SW.063

Published in U.S.A. August 2021

